

# Introduction to the Geometry of the Triangle

Paul Yiu

Summer 2001

Department of Mathematics  
Florida Atlantic University

Version 2.0402 April 2002

# Table of Contents

<b>Chapter 1</b>	The circumcircle and the incircle	1
1.1	Preliminaries	1
1.2	The circumcircle and the incircle of a triangle	4
1.3	Euler's formula and Steiner's porism	9
1.4	Appendix: Constructions with the centers of similitude of the circumcircle and the incircle	11
<b>Chapter 2</b>	The Euler line and the nine-point circle	15
2.1	The Euler line	15
2.2	The nine-point circle	17
2.3	Simson lines and reflections	20
2.4	Appendix: Homothety	21
<b>Chapter 3</b>	Homogeneous barycentric coordinates	25
3.1	Barycentric coordinates with reference to a triangle	25
3.2	Cevians and traces	29
3.3	Isotomic conjugates	31
3.4	Conway's formula	32
3.5	The Kiepert perspectors	34
<b>Chapter 4</b>	Straight lines	43
4.1	The equation of a line	43
4.2	Infinite points and parallel lines	46
4.3	Intersection of two lines	47
4.4	Pedal triangle	51
4.5	Perpendicular lines	54
4.6	Appendix: Excentral triangle and centroid of pedal triangle	58

**Chapter 5** Circles I 61

- 5.1 Isogonal conjugates 61
- 5.2 The circumcircle as the isogonal conjugate of the line at infinity 62
- 5.3 Simson lines 65
- 5.4 Equation of the nine-point circle 67
- 5.5 Equation of a general circle 68
- 5.6 Appendix: Miquel theory 69

**Chapter 6** Circles II 73

- 6.1 Equation of the incircle 73
- 6.2 Intersection of incircle and nine-point circle 74
- 6.3 The excircles 78
- 6.4 The Brocard points 80
- 6.5 Appendix: The circle triad  $(A(a), B(b), C(c))$  83

**Chapter 7** Circles III 87

- 7.1 The distance formula 87
- 7.2 Circle equation 88
- 7.3 Radical circle of a triad of circles 90
- 7.4 The Lucas circles 93
- 7.5 Appendix: More triads of circles 94

**Chapter 8** Some Basic Constructions 97

- 8.1 Barycentric product 97
- 8.2 Harmonic associates 100
- 8.3 Cevian quotient 102
- 8.4 Brocardians 103

<b>Chapter 9</b>	Circumconics	105
9.1	Circumconic as isogonal transform of lines	105
9.2	The infinite points of a circum-hyperbola	108
9.3	The perspector and center of a circumconic	109
9.4	Appendix: Ruler construction of tangent	112
<b>Chapter 10</b>	General Conics	113
10.1	Equation of conics	113
10.2	Inscribed conics	115
10.3	The adjoint of a matrix	116
10.4	Conics parametrized by quadratic equations	117
10.5	The matrix of a conic	118
10.6	The dual conic	119
10.7	The type, center and perspector of a conic	121
<b>Chapter 11</b>	Some Special Conics	125
11.1	Inscribed conic with prescribed foci	125
11.2	Inscribed parabola	127
11.3	Some special conics	129
11.4	Envelopes	133
<b>Chapter 12</b>	Some More Conics	137
12.1	Conics associated with parallel intercepts	137
12.2	Lines simultaneously bisecting perimeter and area	140
12.3	Parabolas with vertices as foci and sides as directrices	142
12.4	The Soddy hyperbolas	143
12.5	Appendix: Constructions with conics	144

# Chapter 1

## The Circumcircle and the Incircle

### 1.1 Preliminaries

#### 1.1.1 Coordinatization of points on a line

Let  $B$  and  $C$  be two fixed points on a line  $\mathcal{L}$ . Every point  $X$  on  $\mathcal{L}$  can be coordinatized in one of several ways:

- (1) the ratio of division  $t = \frac{BX}{XC}$ ,
- (2) the *absolute* barycentric coordinates: an expression of  $X$  as a *convex* combination of  $B$  and  $C$ :

$$X = (1 - t)B + tC,$$

which expresses for an arbitrary point  $P$  outside the line  $\mathcal{L}$ , the vector  $\mathbf{PX}$  as a combination of the vectors  $\mathbf{PB}$  and  $\mathbf{PC}$ .

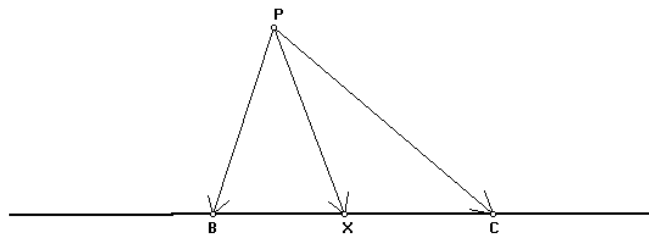

- (3) the *homogeneous* barycentric coordinates: the proportion  $XC : BX$ , which are masses at  $B$  and  $C$  so that the resulting system (of two particles) has *balance point* at  $X$ .

### 1.1.2 Centers of similitude of two circles

Consider two circles  $O(R)$  and  $I(r)$ , whose centers  $O$  and  $I$  are at a distance  $d$  apart. Animate a point  $X$  on  $O(R)$  and construct a ray through  $I$  *oppositely* parallel to the ray  $OX$  to intersect the circle  $I(r)$  at a point  $Y$ . You will find that the line  $XY$  always intersects the line  $OI$  at the same point  $P$ . This we call the *internal center of similitude* of the two circles. It divides the segment  $OI$  in the ratio  $OP : PI = R : r$ . The absolute barycentric coordinates of  $P$  with respect to  $OI$  are

$$P = \frac{R \cdot I + r \cdot O}{R + r}.$$

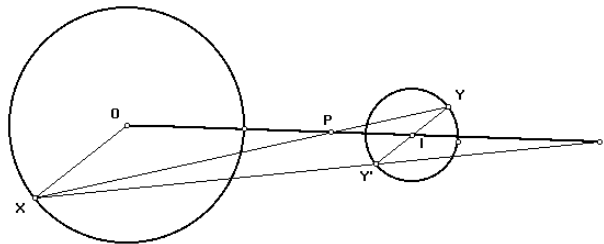

If, on the other hand, we construct a ray through  $I$  *directly* parallel to the ray  $OX$  to intersect the circle  $I(r)$  at  $Y'$ , the line  $XY'$  always intersects  $OI$  at another point  $Q$ . This is the *external center of similitude* of the two circles. It divides the segment  $OI$  in the ratio  $OQ : QI = R : -r$ , and has absolute barycentric coordinates

$$Q = \frac{R \cdot I - r \cdot O}{R - r}.$$

### 1.1.3 Harmonic division

Two points  $X$  and  $Y$  are said to divide two other points  $B$  and  $C$  *harmonically* if

$$\frac{BX}{XC} = -\frac{BY}{YC}.$$

They are *harmonic conjugates* of each other with respect to the segment  $BC$ .

#### Exercises

1. If  $X, Y$  divide  $B, C$  harmonically, then  $B, C$  divide  $X, Y$  harmonically.

2. Given a point  $X$  on the line  $BC$ , construct its harmonic associate with respect to the segment  $BC$ . Distinguish between two cases when  $X$  divides  $BC$  internally and externally.<sup>1</sup>
3. Given two fixed points  $B$  and  $C$ , the locus of the points  $P$  for which  $|BP| : |CP| = k$  (constant) is a circle.

### 1.1.4 Menelaus and Ceva Theorems

Consider a triangle  $ABC$  with points  $X, Y, Z$  on the side lines  $BC, CA, AB$  respectively.

#### Menelaus Theorem

The points  $X, Y, Z$  are collinear if and only if

$$\frac{BX}{XC} \cdot \frac{CY}{YA} \cdot \frac{AZ}{ZB} = -1.$$

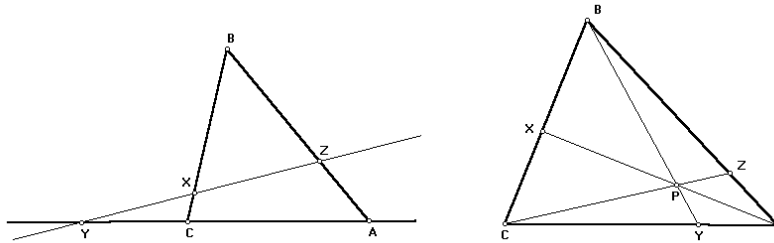

#### Ceva Theorem

The lines  $AX, BY, CZ$  are concurrent if and only if

$$\frac{BX}{XC} \cdot \frac{CY}{YA} \cdot \frac{AZ}{ZB} = +1.$$

#### Ruler construction of harmonic conjugate

Let  $X$  be a point on the line  $BC$ . To construct the harmonic conjugate of  $X$  with respect to the segment  $BC$ , we proceed as follows.

- (1) Take any point  $A$  outside the line  $BC$  and construct the lines  $AB$  and  $AC$ .

---

<sup>1</sup>Make use of the notion of centers of similitude of two circles.

- (2) Mark an arbitrary point  $P$  on the line  $AX$  and construct the lines  $BP$  and  $CP$  to intersect respectively the lines  $CA$  and  $AB$  at  $Y$  and  $Z$ .
- (3) Construct the line  $YZ$  to intersect  $BC$  at  $X'$ .

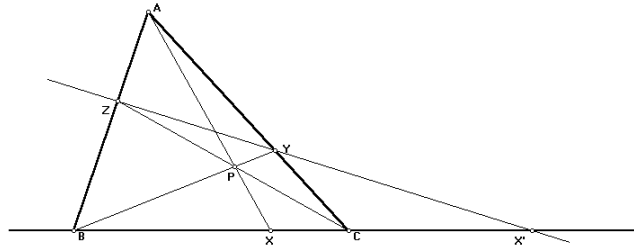

Then  $X$  and  $X'$  divide  $B$  and  $C$  harmonically.

### 1.1.5 The power of a point with respect to a circle

The *power* of a point  $P$  with respect to a circle  $\mathcal{C} = O(R)$  is the quantity  $\mathcal{C}(P) := OP^2 - R^2$ . This is positive, zero, or negative according as  $P$  is outside, on, or inside the circle  $\mathcal{C}$ . If it is positive, it is the square of the length of a tangent from  $P$  to the circle.

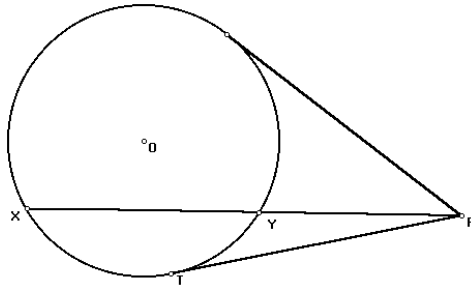

#### Theorem (Intersecting chords)

If a line  $\mathcal{L}$  through  $P$  intersects a circle  $\mathcal{C}$  at two points  $X$  and  $Y$ , the product  $PX \cdot PY$  (of signed lengths) is equal to the power of  $P$  with respect to the circle.

## 1.2 The circumcircle and the incircle of a triangle

For a generic triangle  $ABC$ , we shall denote the lengths of the sides  $BC$ ,  $CA$ ,  $AB$  by  $a$ ,  $b$ ,  $c$  respectively.



### 1.2.1 The circumcircle

The **circumcircle** of triangle  $ABC$  is the unique circle passing through the three vertices  $A, B, C$ . Its center, the **circumcenter**  $O$ , is the intersection of the perpendicular bisectors of the three sides. The circumradius  $R$  is given by the law of sines:

$$2R = \frac{a}{\sin A} = \frac{b}{\sin B} = \frac{c}{\sin C}.$$

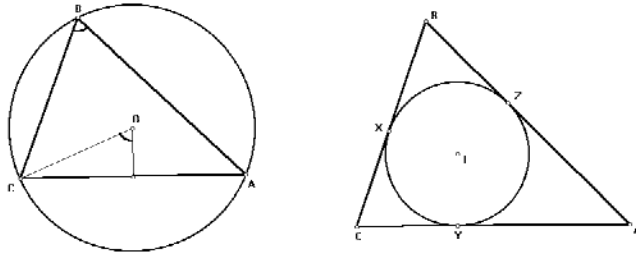

### 1.2.2 The incircle

The **incircle** is tangent to each of the three sides  $BC, CA, AB$  (without extension). Its center, the **incenter**  $I$ , is the intersection of the bisectors of the three angles. The *inradius*  $r$  is related to the area  $\frac{1}{2}S$  by

$$S = (a + b + c)r.$$

If the incircle is tangent to the sides  $BC$  at  $X$ ,  $CA$  at  $Y$ , and  $AB$  at  $Z$ , then

$$AY = AZ = \frac{b + c - a}{2}, \quad BZ = BX = \frac{c + a - b}{2}, \quad CX = CY = \frac{a + b - c}{2}.$$

These expressions are usually simplified by introducing the *semiperimeter*  $s = \frac{1}{2}(a + b + c)$ :

$$AY = AZ = s - a, \quad BZ = BX = s - b, \quad CX = CY = s - c.$$

Also,  $r = \frac{S}{2s}$ .

### 1.2.3 The centers of similitude of $(O)$ and $(I)$

Denote by  $T$  and  $T'$  respectively the internal and external centers of similitude of the circumcircle and incircle of triangle  $ABC$ .

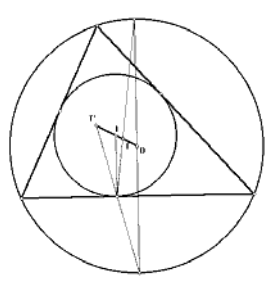

These are points dividing the segment  $OI$  harmonically in the ratios

$$OT : TI = R : r, \quad OT' : T'I = R : -r.$$

#### Exercises

1. Use the Ceva theorem to show that the lines  $AX$ ,  $BY$ ,  $CZ$  are concurrent. (The intersection is called the *Gergonne point* of the triangle).
2. Construct the three circles each passing through the Gergonne point and tangent to two sides of triangle  $ABC$ . The 6 points of tangency lie on a circle.
3. Given three points  $A$ ,  $B$ ,  $C$  not on the same line, construct three circles, with centers at  $A$ ,  $B$ ,  $C$ , mutually tangent to each other *externally*.
4. Two circles are orthogonal to each other if their tangents at an intersection are perpendicular to each other. Given three points  $A$ ,  $B$ ,  $C$  not on a line, construct three circles with these as centers and orthogonal to each other.
5. The centers  $A$  and  $B$  of two circles  $A(a)$  and  $B(b)$  are at a distance  $d$  apart. The line  $AB$  intersect the circles at  $A'$  and  $B'$  respectively, so that  $A$ ,  $B$  are between  $A'$ ,  $B'$ .

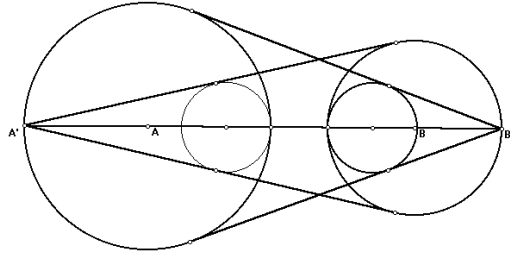

- (1) Construct the tangents from  $A'$  to the circle  $B(b)$ , and the circle tangent to these two lines and to  $A(a)$  internally.
  - (2) Construct the tangents from  $B'$  to the circle  $A(a)$ , and the circle tangent to these two lines and to  $B(b)$  internally.
  - (3) The two circles in (1) and (2) are congruent.
6. Given a point  $Z$  on a line segment  $AB$ , construct a right-angled triangle  $ABC$  whose incircle touches the hypotenuse  $AB$  at  $Z$ .<sup>2</sup>
  7. (Paper Folding) The figure below shows a rectangular sheet of paper containing a border of uniform width. The paper may be any size and shape, but the border must be of such a width that the area of the inner rectangle is exactly half that of the sheet. You have no ruler or compasses, or even a pencil. You must determine the inner rectangle purely by paper folding.<sup>3</sup>

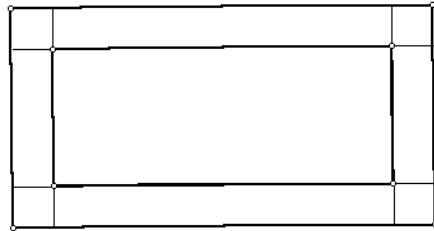

8. Let  $ABC$  be a triangle with incenter  $I$ .
  - (1a) Construct a tangent to the incircle at the point diametrically opposite to its point of contact with the side  $BC$ . Let this tangent intersect  $CA$  at  $Y_1$  and  $AB$  at  $Z_1$ .

<sup>2</sup>P. Yiu, G. Leversha, and T. Seimiya, Problem 2415 and solution, *Cruz Math.* 25 (1999) 110; 26 (2000) 62 – 64.

<sup>3</sup>Problem 2519, *Journal of Recreational Mathematics*, 30 (1999-2000) 151 – 152.

- (1b) Same in part (a), for the side  $CA$ , and let the tangent intersect  $AB$  at  $Z_2$  and  $BC$  at  $X_2$ .
- (1c) Same in part (a), for the side  $AB$ , and let the tangent intersect  $BC$  at  $X_3$  and  $CA$  at  $Y_3$ .
- (2) Note that  $AY_3 = AZ_2$ . Construct the circle tangent to  $AC$  and  $AB$  at  $Y_3$  and  $Z_2$ . How does this circle intersect the circumcircle of triangle  $ABC$ ?
9. The incircle of  $\triangle ABC$  touches the sides  $BC$ ,  $CA$ ,  $AB$  at  $D$ ,  $E$ ,  $F$  respectively.  $X$  is a point inside  $\triangle ABC$  such that the incircle of  $\triangle XBC$  touches  $BC$  at  $D$  also, and touches  $CX$  and  $XB$  at  $Y$  and  $Z$  respectively.
- (1) The four points  $E$ ,  $F$ ,  $Z$ ,  $Y$  are concyclic. <sup>4</sup>
- (2) What is the **locus** of the center of the circle  $EFZY$ ? <sup>5</sup>

#### 1.2.4 The Heron formula

The area of triangle  $ABC$  is given by

$$\frac{S}{2} = \sqrt{s(s-a)(s-b)(s-c)}.$$

This formula can be easily derived from a computation of the inradius  $r$  and the radius of one of the **tritangent circles** of the triangle. Consider the *excircle*  $I_a(r_a)$  whose center is the intersection of the bisector of angle  $A$  and the external bisectors of angles  $B$  and  $C$ . If the incircle  $I(r)$  and this excircle are tangent to the line  $AC$  at  $Y$  and  $Y'$  respectively, then

- (1) from the similarity of triangles  $AIY$  and  $AI_aY'$ ,

$$\frac{r}{r_a} = \frac{s-a}{s};$$

- (2) from the similarity of triangles  $CIY$  and  $I_aCY'$ ,

$$r \cdot r_a = (s-b)(s-c).$$

---

<sup>4</sup>International Mathematical Olympiad 1996.

<sup>5</sup>IMO 1996.

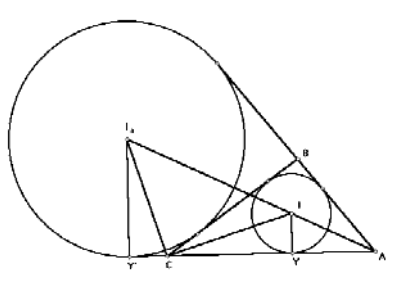

It follows that

$$r = \sqrt{\frac{(s-a)(s-b)(s-c)}{s}}.$$

From this we obtain the famous Heron formula for the area of a triangle:

$$\frac{S}{2} = rs = \sqrt{s(s-a)(s-b)(s-c)}.$$

### Exercises

1.  $R = \frac{abc}{2S}$ .
2.  $r_a = \frac{S}{b+c-a}$ .
3. Suppose the incircle of triangle  $ABC$  touches its sides  $BC$ ,  $CA$ ,  $AB$  at the points  $X$ ,  $Y$ ,  $Z$  respectively. Let  $X'$ ,  $Y'$ ,  $Z'$  be the antipodal points of  $X$ ,  $Y$ ,  $Z$  on the incircle. Construct the rays  $AX'$ ,  $BY'$ , and  $CZ'$ .

Explain the concurrency of these rays by considering also the points of contact of the excircles of the triangle with the sides.

4. Construct the **tritangent circles** of a triangle  $ABC$ .
  - (1) Join each excenter to the midpoint of the corresponding side of  $ABC$ . These three lines intersect at a point  $P$ . (This is called the *Mittenpunkt* of the triangle).
  - (2) Join each excenter to the point of tangency of the incircle with the corresponding side. These three lines are concurrent at another point  $Q$ .
  - (3) The lines  $AP$  and  $AQ$  are symmetric with respect to the bisector of angle  $A$ ; so are the lines  $BP$ ,  $BQ$  and  $CP$ ,  $CQ$  (with respect to the bisectors of angles  $B$  and  $C$ ).

5. Construct the excircles of a triangle  $ABC$ .

(1) Let  $D, E, F$  be the midpoints of the sides  $BC, CA, AB$ . Construct the incenter  $S$  of triangle  $DEF$ ,<sup>6</sup> and the **tangents from  $S$**  to each of the three excircles.

(2) The 6 points of tangency are on a circle, which is *orthogonal* to each of the excircles.

### 1.3 Euler's formula and Steiner's porism

#### 1.3.1 Euler's formula

The distance between the circumcenter and the incenter of a triangle is given by

$$OI^2 = R^2 - 2Rr.$$

Construct the **circumcircle**  $O(R)$  of triangle  $ABC$ . **Bisect** angle  $A$  and **mark** the intersection  $M$  of the bisector with the circumcircle. Construct the circle  $M(B)$  to intersect this bisector at a point  $I$ . This is the incenter since

$$\angle IBC = \frac{1}{2}\angle IMC = \frac{1}{2}\angle AMC = \frac{1}{2}\angle ABC,$$

and for the same reason  $\angle ICB = \frac{1}{2}\angle ACB$ . Note that

(1)  $IM = MB = MC = 2R \sin \frac{A}{2}$ ,

(2)  $IA = \frac{r}{\sin \frac{A}{2}}$ , and

(3) by the theorem of intersecting chords,  $R^2 - OI^2 =$  the *power* of  $I$  with respect to the circumcircle  $= IA \cdot IM = 2Rr$ .

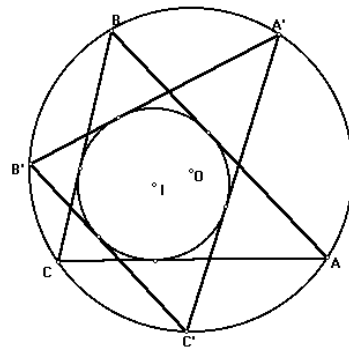
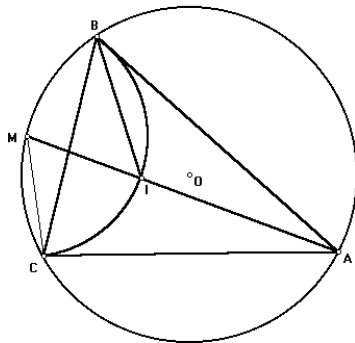

<sup>6</sup>This is called the Spieker point of triangle  $ABC$ .

### 1.3.2 Steiner's porism<sup>7</sup>

Construct the circumcircle ( $O$ ) and the incircle ( $I$ ) of triangle  $ABC$ . **Animate** a point  $A'$  on the circumcircle, and construct the **tangents from  $A'$**  to the incircle ( $I$ ). Extend these tangents to intersect the circumcircle again at  $B'$  and  $C'$ . The lines  $B'C'$  is always tangent to the incircle. This is the famous theorem on Steiner porism: *if two given circles are the circumcircle and incircle of one triangle, then they are the circumcircle and incircle of a continuous family of poristic triangles.*

#### Exercises

1.  $r \leq \frac{1}{2}R$ . When does equality hold?
2. Suppose  $OI = d$ . Show that there is a right-angled triangle whose sides are  $d$ ,  $r$  and  $R - r$ . Which one of these is the hypotenuse?
3. Given a point  $I$  inside a circle  $O(R)$ , construct a circle  $I(r)$  so that  $O(R)$  and  $I(r)$  are the circumcircle and incircle of a (family of poristic) triangle(s).
4. Given the circumcenter, incenter, and one vertex of a triangle, construct the triangle.
5. Construct an animation picture of a triangle whose circumcenter lies on the incircle.<sup>8</sup>

## 1.4 Appendix: Mixtilinear incircles<sup>9</sup>

A mixtilinear incircle of triangle  $ABC$  is one that is tangent to two sides of the triangle and to the circumcircle internally. Denote by  $A'$  the point of tangency of the mixtilinear incircle  $K(\rho)$  in angle  $A$  with the circumcircle. The center  $K$  clearly lies on the bisector of angle  $A$ , and  $AK : KI = \rho : -(\rho - r)$ . In terms of barycentric coordinates,

$$K = \frac{1}{r}[-(\rho - r)A + \rho I].$$

Also, since the circumcircle  $O(A')$  and the mixtilinear incircle  $K(A')$  touch each other at  $A'$ , we have  $OK : KA' = R - \rho : \rho$ , where  $R$  is the circumradius.

<sup>7</sup>Also known as Poncelet's porism.

<sup>8</sup>Hint:  $OI = r$ .

<sup>9</sup>P.Yiu, Mixtilinear incircles, *Amer. Math. Monthly* 106 (1999) 952 – 955.

From this,

$$K = \frac{1}{R}[\rho O + (R - \rho)A'].$$

Comparing these two equations, we obtain, by rearranging terms,

$$\frac{RI - rO}{R - r} = \frac{R(\rho - r)A + r(R - \rho)A'}{\rho(R - r)}.$$

We note some interesting consequences of this formula. First of all, it gives the intersection of the lines joining  $AA'$  and  $OI$ . Note that the point on the line  $OI$  represented by the left hand side is  $T'$ .

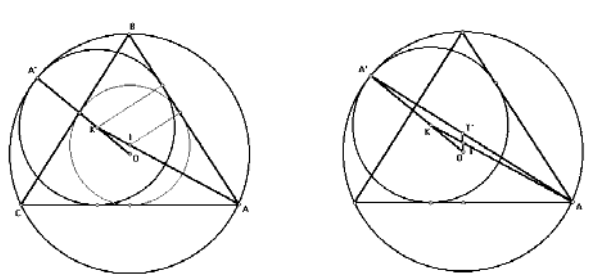

This leads to a simple construction of the mixtilinear incircle:

Given a triangle  $ABC$ , let  $P$  be the external center of similitude of the circumcircle ( $O$ ) and incircle ( $I$ ). Extend  $AP$  to intersect the circumcircle at  $A'$ . The intersection of  $AI$  and  $A'O$  is the center  $K_A$  of the mixtilinear incircle in angle  $A$ .

The other two mixtilinear incircles can be constructed similarly.

### Exercises

1. Can any of the centers of similitude of ( $O$ ) and ( $I$ ) lie outside triangle  $ABC$ ?
2. There are three circles each tangent internally to the circumcircle at a vertex, and externally to the incircle. It is known that the three lines joining the points of tangency of each circle with ( $O$ ) and ( $I$ ) pass through the internal center  $T$  of similitude of ( $O$ ) and ( $I$ ). Construct these three circles.<sup>10</sup>

<sup>10</sup>A.P. Hatzipolakis and P. Yiu, Triads of circles, preprint.



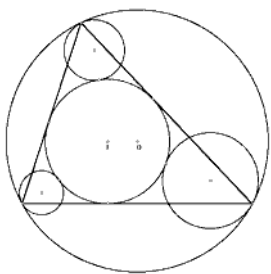

3. Let  $T$  be the *internal* center of similitude of  $(O)$  and  $(I)$ . Suppose  $BT$  intersects  $CA$  at  $Y$  and  $CT$  intersect  $AB$  at  $Z$ . Construct perpendiculars from  $Y$  and  $Z$  to intersect  $BC$  at  $Y'$  and  $Z'$  respectively. Calculate the length of  $Y'Z'$ .<sup>11</sup>

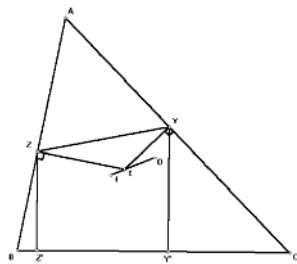

<sup>11</sup>A.P. Hatzipolakis and P. Yiu, Pedal triangles and their shadows, *Forum Geom.*, 1 (2001) 81 – 90.

## Chapter 2

# The Euler Line and the Nine-point Circle

### 2.1 The Euler line

#### 2.1.1 Homothety

The similarity transformation  $h(T, r)$  which carries a point  $X$  to the point  $X'$  which divides  $TX' : TX = r : 1$  is called the *homothety* with center  $T$  and ratio  $r$ .

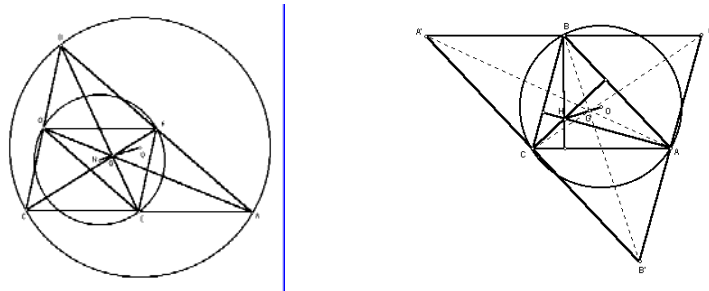

#### 2.1.2 The centroid

The three medians of a triangle intersect at the centroid, which divides each median in the ratio  $2 : 1$ . If  $D, E, F$  are the midpoints of the sides  $BC, CA, AB$  of triangle  $ABC$ , the centroid  $G$  divides the median  $AD$  in the ratio  $AG : GD = 2 : 1$ . The *medial* triangle  $DEF$  is the image of triangle  $ABC$  under the homothety  $h(G, -\frac{1}{2})$ . The circumcircle of the medial triangle has radius  $\frac{1}{2}R$ . Its center is the point  $N = h(G, -\frac{1}{2})(O)$ . This divides the

segment  $OG$  in the ratio  $OG : GN = 2 : 1$ .

### 2.1.3 The orthocenter

The *dilated triangle*  $A'B'C'$  is the image of  $ABC$  under the homothety  $h(G, -2)$ .<sup>1</sup> Since the altitudes of triangle  $ABC$  are the perpendicular bisectors of the sides of triangle  $A'B'C'$ , they intersect at the homothetic image of the circumcenter  $O$ . This point is called the *orthocenter* of triangle  $ABC$ , and is usually denoted by  $H$ . Note that

$$OG : GH = 1 : 2.$$

The line containing  $O, G, H$  is called the Euler line of triangle  $ABC$ . The Euler line is undefined for the equilateral triangle, since these points coincide.

#### Exercises

1. A triangle is equilateral if and only if two of its circumcenter, centroid, and orthocenter coincide.
2. The circumcenter  $N$  of the medial triangle is the midpoint of  $OH$ .
3. The Euler lines of triangles  $HBC, HCA, HAB$  intersect at a point on the Euler line of triangle  $ABC$ . What is this intersection?
4. The Euler lines of triangles  $IBC, ICA, IAB$  also intersect at a point on the Euler line of triangle  $ABC$ .<sup>2</sup>
5. (Gossard's Theorem) Suppose the Euler line of triangle  $ABC$  intersects the side lines  $BC, CA, AB$  at  $X, Y, Z$  respectively. The Euler lines of the triangles  $AYZ, BZX$  and  $CXY$  bound a triangle homothetic to  $ABC$  with ratio  $-1$  and with homothetic center on the Euler line of  $ABC$ .
6. What is the **locus** of the centroids of the poristic triangles with the same circumcircle and incircle of triangle  $ABC$ ? How about the orthocenter?

---

<sup>1</sup>It is also called the anticomplementary triangle.

<sup>2</sup>Problem 1018, *Crux Mathematicorum*.

7. Let  $A'B'C'$  be a poristic triangle with the same circumcircle and incircle of triangle  $ABC$ , and let the sides of  $B'C'$ ,  $C'A'$ ,  $A'B'$  touch the incircle at  $X$ ,  $Y$ ,  $Z$ .
- (i) What is the **locus** of the centroid of  $XYZ$ ?
  - (ii) What is the **locus** of the orthocenter of  $XYZ$ ?
  - (iii) What can you say about the Euler line of the triangle  $XYZ$ ?

## 2.2 The nine-point circle

### 2.2.1 The Euler triangle as a midway triangle

The image of  $ABC$  under the homothety  $h(P, \frac{1}{2})$  is called the *midway triangle* of  $P$ . The midway triangle of the orthocenter  $H$  is called the *Euler triangle*. The circumcenter of the midway triangle of  $P$  is the midpoint of  $OP$ . In particular, the circumcenter of the Euler triangle is the midpoint of  $OH$ , which is the same as  $N$ . *The medial triangle and the Euler triangle have the same circumcircle.*

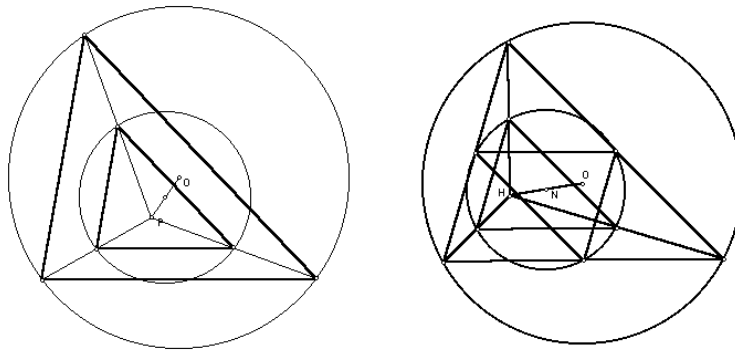

### 2.2.2 The orthic triangle as a pedal triangle

The *pedals* of a point are the intersections of the sidelines with the corresponding perpendiculars through  $P$ . They form the *pedal triangle* of  $P$ . The pedal triangle of the orthocenter  $H$  is called the *orthic triangle* of  $ABC$ .

The pedal  $X$  of the orthocenter  $H$  on the side  $BC$  is also the pedal of  $A$  on the same line, and can be regarded as the *reflection* of  $A$  in the line  $EF$ . It follows that

$$\angle EXF = \angle EAF = \angle EDF,$$

since  $AEDF$  is a parallelogram. From this, the point  $X$  lies on the circle  $DEF$ ; similarly for the pedals  $Y$  and  $Z$  of  $H$  on the other two sides  $CA$  and  $AB$ .

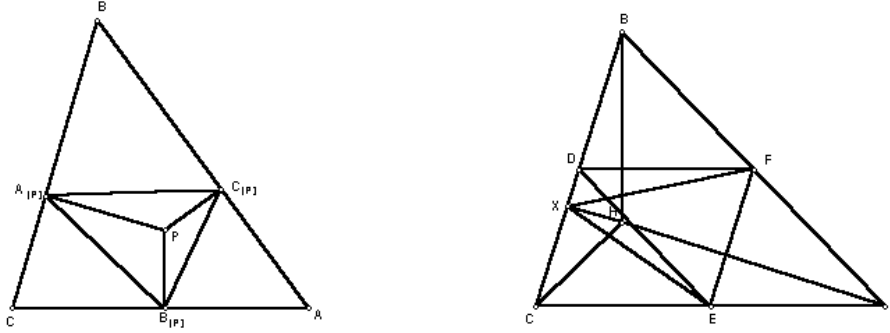

### 2.2.3 The nine-point circle

From §2.2.1,2 above, the medial triangle, the Euler triangle, and the orthic triangle have the same circumcircle. This is called the *nine-point circle* of triangle  $ABC$ . Its center  $N$ , the midpoint of  $OH$ , is called the *nine-point center* of triangle  $ABC$ .

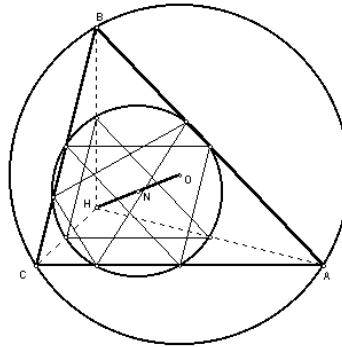

#### Exercises

1. On the Euler line,

$$OG : GN : NH = 2 : 1 : 3.$$

2. Let  $P$  be a point on the circumcircle. What is the **locus** of the midpoint of  $HP$ ? Can you give a proof?

3. Let  $ABC$  be a triangle and  $P$  a point. The perpendiculars at  $P$  to  $PA$ ,  $PB$ ,  $PC$  intersect  $BC$ ,  $CA$ ,  $AB$  respectively at  $A'$ ,  $B'$ ,  $C'$ .
- (1)  $A'$ ,  $B'$ ,  $C'$  are collinear.<sup>3</sup>
  - (2) The nine-point circles of the (right-angled) triangles  $PAA'$ ,  $PBB'$ ,  $PCC'$  are concurrent at  $P$  and another point  $P'$ . Equivalently, their centers are collinear.<sup>4</sup>
4. If the midpoints of  $AP$ ,  $BP$ ,  $CP$  are all on the nine-point circle, must  $P$  be the orthocenter of triangle  $ABC$ ?<sup>5</sup>
5. (Paper folding) Let  $N$  be the nine-point center of triangle  $ABC$ .
- (1) Fold the perpendicular to  $AN$  at  $N$  to intersect  $CA$  at  $Y$  and  $AB$  at  $Z$ .
  - (2) Fold the reflection  $A'$  of  $A$  in the line  $YZ$ .
  - (3) Fold the reflections of  $B$  in  $A'Z$  and  $C$  in  $A'Y$ .
- What do you observe about these reflections?

### 2.2.4 Triangles with nine-point center on the circumcircle

We begin with a circle, center  $O$  and a point  $N$  on it, and construct a family of triangles with ( $O$ ) as circumcircle and  $N$  as nine-point center.

- (1) Construct the nine-point circle, which has center  $N$ , and passes through the midpoint  $M$  of  $ON$ .
- (2) **Animate** a point  $D$  on the minor arc of the nine-point circle *inside* the circumcircle.
- (3) Construct the chord  $BC$  of the circumcircle with  $D$  as midpoint. (This is simply the perpendicular to  $OD$  at  $D$ ).
- (4) Let  $X$  be the point on the nine-point circle antipodal to  $D$ . Complete the parallelogram  $ODXA$  (by **translating** the vector  $\mathbf{DO}$  to  $X$ ).

The point  $A$  lies on the circumcircle and the triangle  $ABC$  has nine-point center  $N$  on the circumcircle.

Here is an curious property of triangles constructed in this way: let  $A'$ ,  $B'$ ,  $C'$  be the reflections of  $A$ ,  $B$ ,  $C$  in their own opposite sides. The

<sup>3</sup>B. Gibert, Hyacinthos 1158, 8/5/00.

<sup>4</sup>A.P. Hatzipolakis, Hyacinthos 3166, 6/27/01. The three midpoints of  $AA'$ ,  $BB'$ ,  $CC'$  are collinear. The three nine-point circles intersect at  $P$  and its pedal on this line.

<sup>5</sup>Yes. See P. Yiu and J. Young, Problem 2437 and solution, *Cruz Math.* 25 (1999) 173; 26 (2000) 192.

reflection triangle  $A'B'C'$  degenerates, *i.e.*, the three points  $A'$ ,  $B'$ ,  $C'$  are collinear.<sup>6</sup>

## 2.3 Simson lines and reflections

### 2.3.1 Simson lines

Let  $P$  on the circumcircle of triangle  $ABC$ .

(1) Construct its pedals on the side lines. These pedals are always collinear. The line containing them is called the *Simson line*  $s(P)$  of  $P$ .

(2) Let  $P'$  be the point on the circumcircle antipodal to  $P$ . Construct the Simson line  $s(P')$  and **trace** the intersection point  $s(P) \cap s(P')$ . Can you identify this locus?

(3) Let the Simson line  $s(P)$  intersect the side lines  $BC$ ,  $CA$ ,  $AB$  at  $X$ ,  $Y$ ,  $Z$  respectively. The circumcenters of the triangles  $AYZ$ ,  $BZX$ , and  $CXY$  form a triangle homothetic to  $ABC$  at  $P$ , with ratio  $\frac{1}{2}$ . These circumcenters therefore lie on a circle tangent to the circumcircle at  $P$ .

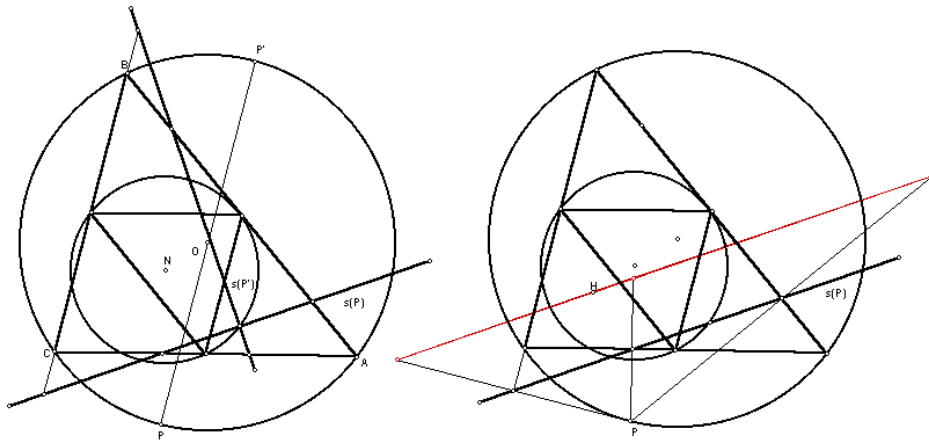

### 2.3.2 Line of reflections

Construct the **reflections** of the  $P$  in the side lines. These reflections are always collinear, and the line containing them always passes through the orthocenter  $H$ , and is parallel to the Simson line  $s(P)$ .

<sup>6</sup>O. Bottema, *Hoofdstukken uit de Elementaire Meetkunde*, Chapter 16.

### 2.3.3 Musselman's Theorem: Point with given line of reflections

Let  $\mathcal{L}$  be a line through the orthocenter  $H$ .

- (1) Choose an arbitrary point  $Q$  on the line  $\mathcal{L}$  and **reflect** it in the side lines  $BC$ ,  $CA$ ,  $AB$  to obtain the points  $X$ ,  $Y$ ,  $Z$ .
- (2) Construct the circumcircles of  $AYZ$ ,  $BZX$  and  $CXY$ . These circles have a common point  $P$ , which happens to lie on the circumcircle.
- (3) Construct the reflections of  $P$  in the side lines of triangle  $ABC$ .

### 2.3.4 Musselman's Theorem: Point with given line of reflections (Alternative)

Animate a point  $Q$  on the circumcircle, together with its antipode  $Q'$ .

- (1) The **reflections**  $X$ ,  $Y$ ,  $Z$  of  $Q$  on the side lines  $BC$ ,  $CA$ ,  $AB$  are collinear; so are those  $X'$ ,  $Y'$ ,  $Z'$  of  $Q'$ .
- (2) The lines  $XX'$ ,  $YY'$ ,  $ZZ'$  intersect at a point  $P$ , which happens to be on the circumcircle.
- (3) Construct the reflections of  $P$  in the side lines of triangle  $ABC$ .

### 2.3.5 Blanc's Theorem

Animate a point  $P$  on the circumcircle, together with its antipodal point  $P'$ .

- (1) Construct the line  $PP'$  to intersect the side lines  $BC$ ,  $CA$ ,  $AB$  at  $X$ ,  $Y$ ,  $Z$  respectively.
- (2) Construct the circles with diameters  $AX$ ,  $BY$ ,  $CZ$ . These three circles have two common points. One of these is on the circumcircle. Label this point  $P^*$ , and the other common point  $Q$ .
- (3) What is the **locus** of  $Q$ ?
- (4) The line  $P^*Q$  passes through the orthocenter  $H$ . As such, it is the line of reflection of a point on the circumcircle. What is this point?
- (5) Construct the Simson lines of  $P$  and  $P'$ . They intersect at a point on the nine-point circle. What is this point?

### Exercises

1. Let  $P$  be a given point, and  $A'B'C'$  the homothetic image of  $ABC$  under  $h(P, -1)$  (so that  $P$  is the common midpoint of  $AA'$ ,  $BB'$  and  $CC'$ ).



- (1) The circles  $AB'C'$ ,  $BC'A'$  and  $CA'B'$  intersect at a point  $Q$  on the circumcircle;
- (2) The circles  $ABC'$ ,  $BCA'$  and  $CAB'$  intersect at a point  $Q'$  such that  $P$  is the midpoint of  $QQ'$ .<sup>7</sup>

## 2.4 Appendix: Homothety

Two triangles are homothetic if the corresponding sides are parallel.

### 2.4.1 Three congruent circles with a common point and each tangent to two sides of a triangle<sup>8</sup>

Given a triangle  $ABC$ , to construct three congruent circles passing through a common point  $P$ , each tangent to two sides of the triangle.

Let  $t$  be the common radius of these congruent circles. The centers of these circles,  $I_1, I_2, I_3$ , lie on the bisectors  $IA, IB, IC$  respectively. Note that the lines  $I_2I_3$  and  $BC$  are parallel; so are the pairs  $I_3I_1, CA$ , and  $I_1I_2, AB$ . It follows that  $\triangle I_1I_2I_3$  and  $ABC$  are similar. Indeed, they are in *homothetic* from their common incenter  $I$ . The ratio of homothety can be determined in two ways, by considering their circumcircles and their incircles. Since the circumradii are  $t$  and  $R$ , and the inradii are  $r - t$  and  $r$ , we have  $\frac{r-t}{r} = \frac{r}{R}$ . From this,  $t = \frac{Rr}{R+r}$ .

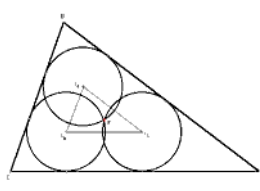

<sup>7</sup>Musselman, *Amer. Math. Monthly*, 47 (1940) 354 – 361. If  $P = (u : v : w)$ , the intersection of the three circles in (1) is the point

$$\left( \frac{1}{b^2(u+v-w)w - c^2(w+u-v)v} : \cdots : \cdots \right)$$

on the circumcircle. This is the isogonal conjugate of the infinite point of the line

$$\sum_{\text{cyclic}} \frac{u(v+w-u)}{a^2} x = 0.$$

<sup>8</sup>Problem 2137, *Cruz Mathematicorum*.

How does this help constructing the circles? Note that the line joining the circumcenters  $P$  and  $O$  passes through the center of homothety  $I$ , and indeed,

$$OI : IP = R : t = R : \frac{Rr}{R+r} = R+r : r.$$

Rewriting this as  $OP : PI = R : r$ , we see that  $P$  is indeed the internal center of similitude of  $(O)$  and  $(I)$ .

Now the construction is easy.

### 2.4.2 Squares inscribed in a triangle and the Lucas circles

Given a triangle  $ABC$ , to construct the inscribed square with a side along  $BC$  we contract the square erected externally on the same side by a homothety at vertex  $A$ . The ratio of the homothety is  $h_a : h_a + a$ , where  $h_a$  is the altitude on  $BC$ . Since  $h_a = \frac{S}{a}$ , we have

$$\frac{h_a}{h_a + a} = \frac{S}{S + a^2}.$$

The circumcircle is contracted into a circle of radius

$$R_a = R \cdot \frac{S}{S + a^2} = \frac{abc}{2S} \cdot \frac{S}{S + a^2} = \frac{abc}{2(S + a^2)},$$

and this passes through the two vertices of the inscribed on the sides  $AB$  and  $AC$ . Similarly, there are two other inscribed squares on the sides  $CA$  and  $AB$ , and two corresponding circles, tangent to the circumcircle at  $B$  and  $C$  respectively. It is remarkable that these three circles are mutually tangent to each other. These are called the Lucas circles of the triangle.<sup>9</sup>

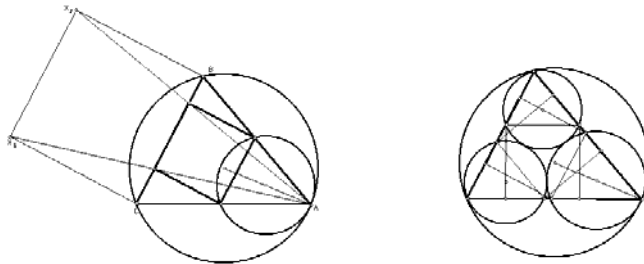

<sup>9</sup>See A.P. Hatzipolakis and P. Yiu, The Lucas circles, *Amer. Math. Monthly*, 108 (2001) 444 – 446. After the publication of this note, we recently learned that Eduoard Lucas (1842 – 1891) wrote about this triad of circles, considered by an anonymous author, as the three circles mutually tangent to each other and each tangent to the circumcircle at a vertex of  $ABC$ . The connection with the inscribed squares were found by Victor Thébault (1883 – 1960).

### 2.4.3 More on reflections

(1) The reflections of a line  $\mathcal{L}$  in the side lines of triangle  $ABC$  are concurrent if and only if  $\mathcal{L}$  passes through the orthocenter. In this case, the intersection is a point on the circumcircle.<sup>10</sup>

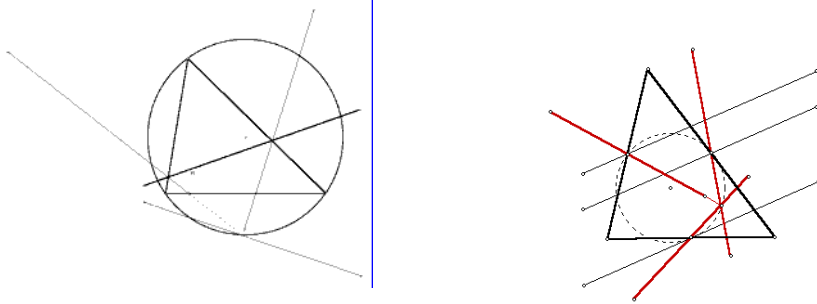

(2) Construct *parallel* lines  $\mathcal{L}_a$ ,  $\mathcal{L}_b$ , and  $\mathcal{L}_c$  through the  $D$ ,  $E$ ,  $F$  be the midpoints of the sides  $BC$ ,  $CA$ ,  $AB$  of triangle  $ABC$ . **Reflect** the lines  $BC$  in  $\mathcal{L}_a$ ,  $CA$  in  $\mathcal{L}_b$ , and  $AB$  in  $\mathcal{L}_c$ . These three reflection lines intersect at a point on the nine-point circle.<sup>11</sup>

(3) Construct *parallel* lines  $\mathcal{L}_a$ ,  $\mathcal{L}_b$ , and  $\mathcal{L}_c$  through the pedals of the vertices  $A$ ,  $B$ ,  $C$  on their opposite sides. Reflect these lines in the respective side lines of triangle  $ABC$ . The three reflection lines intersect at a point on the nine-point circle.<sup>12</sup>

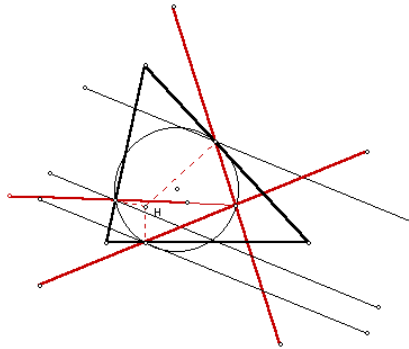

<sup>10</sup>S.N. Collings, Reflections on a triangle, part 1, *Math. Gazette*, 57 (1973) 291 – 293; M.S. Longuet-Higgins, Reflections on a triangle, part 2, *ibid.*, 293 – 296.

<sup>11</sup>This was first discovered in May, 1999 by a high school student, Adam Bliss, in Atlanta, Georgia. A proof can be found in F.M. van Lamoen, Morley related triangles on the nine-point circle, *Amer. Math. Monthly*, 107 (2000) 941 – 945. See also, B. Shawyer, A remarkable concurrence, *Forum Geom.*, 1 (2001) 69 – 74.

<sup>12</sup>*Ibid.*

## Chapter 3

# Homogeneous Barycentric Coordinates

### 3.1 Barycentric coordinates with reference to a triangle

#### 3.1.1 Homogeneous barycentric coordinates

The notion of barycentric coordinates dates back to Möbius. In a given triangle  $ABC$ , every point  $P$  is coordinatized by a triple of numbers  $(u : v : w)$  in such a way that the system of masses  $u$  at  $A$ ,  $v$  at  $B$ , and  $w$  at  $C$  will have its *balance point* at  $P$ . These masses can be taken in the proportions of the areas of triangle  $PBC$ ,  $PCA$  and  $PAB$ . Allowing the point  $P$  to be outside the triangle, we use *signed areas* of oriented triangles. The *homogeneous barycentric coordinates* of  $P$  with reference to  $ABC$  is a triple of numbers  $(x : y : z)$  such that

$$x : y : z = \Delta PBC : \Delta PCA : \Delta PAB.$$

#### Examples

1. The *centroid*  $G$  has homogeneous barycentric coordinates  $(1 : 1 : 1)$ . The areas of the triangles  $GBC$ ,  $GCA$ , and  $GAB$  are equal.<sup>1</sup>
2. The *incenter*  $I$  has homogeneous barycentric coordinates  $(a : b : c)$ . If  $r$  denotes the inradius, the areas of triangles  $IBC$ ,  $ICA$  and  $IAB$  are respectively  $\frac{1}{2}ra$ ,  $\frac{1}{2}rb$ , and  $\frac{1}{2}rc$ .<sup>2</sup>

---

<sup>1</sup>In Kimberling's Encyclopedia of Triangle Centers, [ETC], the centroid appears as  $X_2$ .

<sup>2</sup>In ETC, the incenter appears as  $X_1$ .

3. The *circumcenter*. If  $R$  denotes the circumradius, the coordinates of the circumcenter  $O$  are <sup>3</sup>

$$\begin{aligned}
 & \triangle OBC : \triangle OCA : \triangle OAB \\
 = & \frac{1}{2}R^2 \sin 2A : \frac{1}{2}R^2 \sin 2B : \frac{1}{2}R^2 \sin 2C \\
 = & \sin A \cos A : \sin B \cos B : \sin C \cos C \\
 = & a \cdot \frac{b^2 + c^2 - a^2}{2bc} : b \cdot \frac{c^2 + a^2 - b^2}{2ca} : \frac{a^2 + b^2 - c^2}{2ab} \\
 = & a^2(b^2 + c^2 - a^2) : b^2(c^2 + a^2 - b^2) : c^2(a^2 + b^2 - c^2).
 \end{aligned}$$

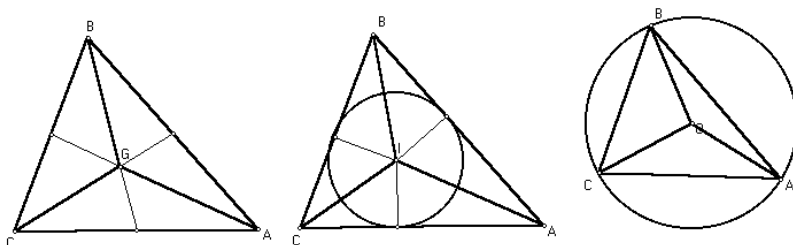

4. Points on the line  $BC$  have coordinates of the form  $(0 : y : z)$ . Likewise, points on  $CA$  and  $AB$  have coordinates of the forms  $(x : 0 : z)$  and  $(x : y : 0)$  respectively.

### Exercise

1. Verify that the sum of the coordinates of the circumcenter given above is  $4S^2$ :

$$a^2(b^2 + c^2 - a^2) + b^2(c^2 + a^2 - b^2) + c^2(a^2 + b^2 - c^2) = 4S^2,$$

where  $S$  is twice the area of triangle  $ABC$ .

2. Find the coordinates of the excenters. <sup>4</sup>

<sup>3</sup>In ETC, the circumcenter appears as  $X_3$ .

<sup>4</sup> $I_a = (-a : b : c)$ ,  $I_b = (a : -b : c)$ ,  $I_c = (a : b : -c)$ .

### 3.1.2 Absolute barycentric coordinates

Let  $P$  be a point with (homogeneous barycentric) coordinates  $(x : y : z)$ . If  $x + y + z \neq 0$ , we obtain the *absolute* barycentric coordinates by scaling the coefficients to have a unit sum:

$$P = \frac{x \cdot A + y \cdot B + z \cdot C}{x + y + z}.$$

If  $P$  and  $Q$  are given in absolute barycentric coordinates, the point  $X$  which divides  $PQ$  in the ratio  $PX : XQ = p : q$  has absolute barycentric coordinates  $\frac{q \cdot P + p \cdot Q}{p + q}$ . It is, however, convenient to perform calculations avoiding denominators of fractions. We therefore adapt this formula in the following way: if  $P = (u : v : w)$  and  $Q = (u' : v' : w')$  are the homogeneous barycentric coordinates satisfying  $u + v + w = u' + v' + w'$ , the point  $X$  dividing  $PQ$  in the ratio  $PX : XQ = p : q$  has homogeneous barycentric coordinates

$$(qu + pu' : qv + pv' : qw + pw').$$

#### Example: Internal center of similitudes of the circumcircle and the incircle

These points,  $T$  and  $T'$ , divide the segment  $OI$  harmonically in the ratio of the circumradius  $R = \frac{abc}{2S}$  and the inradius  $\frac{S}{2s}$ . Note that  $R : r = \frac{abc}{2S} : \frac{S}{2s} = abc : S^2$ .

Since

$$O = (a^2(b^2 + c^2 - a^2) : \dots : \dots)$$

with coordinates sum  $4S^2$  and  $I = (a : b : c)$  with coordinates sum  $2s$ , we equalize their sums and work with

$$\begin{aligned} O &= (sa^2(b^2 + c^2 - a^2) : \dots : \dots), \\ I &= (2S^2a : 2S^2b : 2S^2c). \end{aligned}$$

The internal center of similitude  $T$  divides  $OI$  in the ratio  $OT : TI = R : r$ , the  $a$ -component of its homogeneous barycentric coordinates can be taken as

$$S^2 \cdot sa^2(b^2 + c^2 - a^2) + abc \cdot 2S^2a.$$

The simplification turns out to be easier than we would normally expect:

$$\begin{aligned} &S^2 \cdot sa^2(b^2 + c^2 - a^2) + abc \cdot 2S^2a \\ &= sS^2a^2(b^2 + c^2 - a^2 + 2bc) \end{aligned}$$

$$\begin{aligned}
&= sS^2 a^2 ((b+c)^2 - a^2) \\
&= sS^2 a^2 (b+c+a)(b+c-a) \\
&= 2s^2 S^2 \cdot a^2 (b+c-a).
\end{aligned}$$

The other two components have similar expressions obtained by *cyclically permuting*  $a, b, c$ . It is clear that  $2s^2 S^2$  is a factor common to the three components. Thus, the homogeneous barycentric coordinates of the internal center of similitude are <sup>5</sup>

$$(a^2(b+c-a) : b^2(c+a-b) : c^2(a+b-c)).$$

### Exercises

1. The external center of similitude of  $(O)$  and  $(I)$  has homogeneous barycentric coordinates <sup>6</sup>

$$(a^2(a+b-c)(c+a-b) : b^2(b+c-a)(a+b-c) : c^2(c+a-b)(b+c-a)),$$

which can be taken as

$$\left( \frac{a^2}{b+c-a} : \frac{b^2}{c+a-b} : \frac{c^2}{a+b-c} \right).$$

2. The orthocenter  $H$  lies on the Euler line and divides the segment  $OG$  externally in the ratio  $OH : HG = 3 : -2$ . <sup>7</sup> Show that its homogeneous barycentric coordinates can be written as

$$H = (\tan A : \tan B : \tan C),$$

or equivalently,

$$H = \left( \frac{1}{b^2 + c^2 - a^2} : \frac{1}{c^2 + a^2 - b^2} : \frac{1}{a^2 + b^2 - c^2} \right).$$

3. Make use of the fact that the nine-point center  $N$  divides the segment  $OG$  in the ratio  $ON : GN = 3 : -1$  to show that its barycentric coordinates can be written as <sup>8</sup>

$$N = (a \cos(B-C) : b \cos(C-A) : c \cos(A-B)).$$

---

<sup>5</sup>In ETC, the internal center of similitude of the circumcircle and the incircle appears as the point  $X_{55}$ .

<sup>6</sup>In ETC, the external center of similitude of the circumcircle and the incircle appears as the point  $X_{56}$ .

<sup>7</sup>In ETC, the orthocenter appears as the point  $X_4$ .

<sup>8</sup>In ETC, the nine-point center appears as the point  $X_5$ .

## 3.2 Cevians and traces

Because of the fundamental importance of the Ceva theorem in triangle geometry, we shall follow traditions and call the three lines joining a point  $P$  to the vertices of the reference triangle  $ABC$  the *cevians* of  $P$ . The intersections  $A_P$ ,  $B_P$ ,  $C_P$  of these cevians with the side lines are called the *traces* of  $P$ . The coordinates of the traces can be very easily written down:

$$A_P = (0 : y : z), \quad B_P = (x : 0 : z), \quad C_P = (x : y : 0).$$

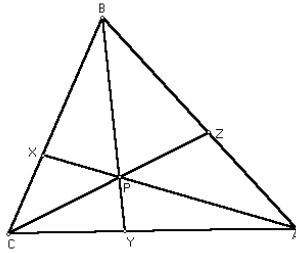

### 3.2.1 Ceva Theorem

Three points  $X$ ,  $Y$ ,  $Z$  on  $BC$ ,  $CA$ ,  $AB$  respectively are the traces of a point if and only if they have coordinates of the form

$$\begin{aligned} X &= 0 : y : z, \\ Y &= x : 0 : z, \\ Z &= x : y : 0, \end{aligned}$$

for some  $x$ ,  $y$ ,  $z$ .

### 3.2.2 Examples

#### The Gergonne point

The points of tangency of the incircle with the side lines are

$$\begin{aligned} X &= 0 : s - c : s - b, \\ Y &= s - c : 0 : s - a, \\ Z &= s - b : s - a : 0. \end{aligned}$$

These can be reorganized as

$$\begin{aligned} X &= 0 : \frac{1}{s-b} : \frac{1}{s-c}, \\ Y &= \frac{1}{s-a} : 0 : \frac{1}{s-c}, \\ Z &= \frac{1}{s-a} : \frac{1}{s-b} : 0. \end{aligned}$$



It follows that  $AX$ ,  $BY$ ,  $CZ$  intersect at a point with coordinates

$$\left( \frac{1}{s-a} : \frac{1}{s-b} : \frac{1}{s-c} \right).$$

This is called the *Gergonne point*  $G_e$  of triangle  $ABC$ .<sup>9</sup>

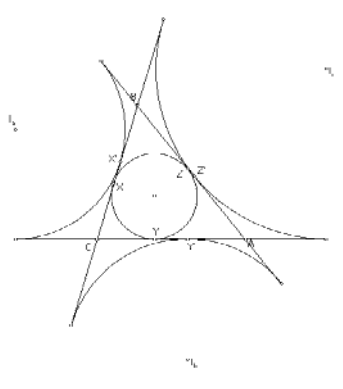

### The Nagel point

The points of tangency of the excircles with the corresponding sides have coordinates

$$\begin{aligned} X' &= (0 : s-b : s-c), \\ Y' &= (s-a : 0 : s-c), \\ Z' &= (s-a : s-b : 0). \end{aligned}$$

These are the traces of the point with coordinates

$$(s-a : s-b : s-c).$$

This is the *Nagel point*  $N_a$  of triangle  $ABC$ .<sup>10</sup>

### Exercises

1. The Nagel point  $N_a$  lies on the line joining the incenter to the centroid; it divides  $IG$  in the ratio  $IN_a : N_aG = 3 : -2$ .

<sup>9</sup>The Gergonne point appears in ETC as the point  $X_7$ .

<sup>10</sup>The Nagel point appears in ETC as the point  $X_8$ .

### 3.3 Isotomic conjugates

The Gergonne and Nagel points are examples of isotomic conjugates. Two points  $P$  and  $Q$  (not on any of the side lines of the reference triangle) are said to be isotomic conjugates if their respective traces are symmetric with respect to the midpoints of the corresponding sides. Thus,

$$BA_P = A_QC, \quad CB_P = B_QA, \quad AC_P = C_QB.$$

We shall denote the isotomic conjugate of  $P$  by  $P^\bullet$ . If  $P = (x : y : z)$ , then

$$P^\bullet = \left(\frac{1}{x} : \frac{1}{y} : \frac{1}{z}\right)$$

#### 3.3.1 Equal-parallelian point

Given triangle  $ABC$ , we want to construct a point  $P$  the three lines through which parallel to the sides cut out equal intercepts. Let  $P = xA + yB + zC$  in absolute barycentric coordinates. The parallel to  $BC$  cuts out an intercept of length  $(1 - x)a$ . It follows that the three intercepts parallel to the sides are equal if and only if

$$1 - x : 1 - y : 1 - z = \frac{1}{a} : \frac{1}{b} : \frac{1}{c}.$$

The right hand side clearly gives the homogeneous barycentric coordinates of  $I^\bullet$ , the isotomic conjugate of the incenter  $I$ .<sup>11</sup> This is a point we can easily construct. Now, translating into *absolute* barycentric coordinates:

$$I^\bullet = \frac{1}{2}[(1 - x)A + (1 - y)B + (1 - z)C] = \frac{1}{2}(3G - P).$$

we obtain  $P = 3G - 2I^\bullet$ , and can be easily constructed as the point dividing the segment  $I^\bullet G$  externally in the ratio  $I^\bullet P : PG = 3 : -2$ . The point  $P$  is called the equal-parallelian point of triangle  $ABC$ .<sup>12</sup>

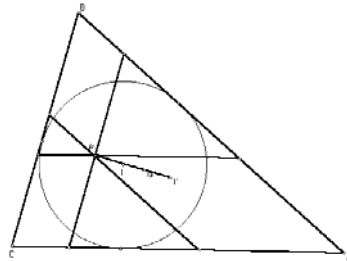

<sup>11</sup>The isotomic conjugate of the incenter appears in ETC as the point  $X_{75}$ .

<sup>12</sup>It appears in ETC as the point  $X_{192}$ .

**Exercises**

1. Calculate the homogeneous barycentric coordinates of the equal-parallelian point and the length of the equal parallelians. <sup>13</sup>
2. Let  $A'B'C'$  be the midway triangle of a point  $P$ . The line  $B'C'$  intersects  $CA$  at

$$\begin{aligned} B_a &= B'C' \cap CA, & C_a &= B'C' \cap AB, \\ C_b &= C'A' \cap AB, & A_b &= C'A' \cap BC, \\ A_c &= A'B' \cap BC, & B_c &= A'B' \cap CA. \end{aligned}$$

Determine  $P$  for which the three segments  $B_aC_a$ ,  $C_bA_b$  and  $A_cB_c$  have equal lengths. <sup>14</sup>

**3.3.2 Yff's analogue of the Brocard points**

Consider a point  $P = (x : y : z)$  satisfying  $BA_P = CB_P = AC_P = w$ . This means that

$$\frac{z}{y+z}a = \frac{x}{z+x}b = \frac{y}{x+y}c = w.$$

Elimination of  $x, y, z$  leads to

$$0 = \begin{vmatrix} -w & a-w \\ b-w & -w \\ -w & c-w \end{vmatrix} = (a-w)(b-w)(c-w) - w^3.$$

Indeed,  $w$  is the unique positive root of the cubic polynomial

$$(a-t)(b-t)(c-t) - t^3.$$

This gives the point

$$P = \left( \left( \frac{c-w}{b-w} \right)^{\frac{1}{3}} : \left( \frac{a-w}{c-w} \right)^{\frac{1}{3}} : \left( \frac{b-w}{a-w} \right)^{\frac{1}{3}} \right).$$

The isotomic conjugate

$$P^\bullet = \left( \left( \frac{b-w}{c-w} \right)^{\frac{1}{3}} : \left( \frac{c-w}{a-w} \right)^{\frac{1}{3}} : \left( \frac{a-w}{b-w} \right)^{\frac{1}{3}} \right)$$

---

<sup>13</sup> $(ca + ab - bc : ab + bc - ca : bc + ca - ab)$ . The common length of the equal parallelians is  $\frac{2abc}{ab+bc+ca}$ .

<sup>14</sup>A.P. Hatzipolakis, Hyacinthos, message 3190, 7/13/01.  $P = (3bc - ca - ab : 3ca - ab - bc : 3ab - bc - ca)$ . This point is not in the current edition of ETC. It is the reflection of the equal-parallelian point in  $I^\bullet$ . In this case, the common length of the segment is  $\frac{2abc}{ab+bc+ca}$ , as in the equal-parallelian case.

satisfies

$$CA_P = AB_P = BC_P = w.$$

These points are usually called the *Yff analogues of the Brocard points*.<sup>15</sup> They were briefly considered by A.L. Crelle.<sup>16</sup>

### 3.4 Conway's formula

#### 3.4.1 Notation

Let  $S$  denote *twice* the area of triangle  $ABC$ . For a real number  $\theta$ , denote  $S \cdot \cot \theta$  by  $S_\theta$ . In particular,

$$S_A = \frac{b^2 + c^2 - a^2}{2}, \quad S_B = \frac{c^2 + a^2 - b^2}{2}, \quad S_C = \frac{a^2 + b^2 - c^2}{2}.$$

For arbitrary  $\theta$  and  $\varphi$ , we shall simply write  $S_{\theta\varphi}$  for  $S_\theta \cdot S_\varphi$ .

We shall mainly make use of the following relations.

#### Lemma

- (1)  $S_B + S_C = a^2$ ,  $S_C + S_A = b^2$ ,  $S_A + S_B = c^2$ .
- (2)  $S_{AB} + S_{BC} + S_{CA} = S^2$ .

*Proof.* (1) is clear. For (2), since  $A + B + C = 180^\circ$ ,  $\cot(A + B + C)$  is infinite. Its denominator

$$\cot A \cdot \cot B + \cot B \cdot \cot C + \cot C \cdot \cot A - 1 = 0.$$

From this,  $S_{AB} + S_{BC} + S_{CA} = S^2(\cot A \cdot \cot B + \cot B \cdot \cot C + \cot C \cdot \cot A) = S^2$ .

#### Examples

- (1) The orthocenter has coordinates

$$\left( \frac{1}{S_A} : \frac{1}{S_B} : \frac{1}{S_C} \right) = (S_{BC} : S_{CA} : S_{AB}).$$

<sup>15</sup>P. Yff, An analogue of the Brocard points, *Amer. Math. Monthly*, 70 (1963) 495 – 501.

<sup>16</sup>A.L. Crelle, 1815.

Note that in the last expression, the coordinate sum is  $S_{BC} + S_{CA} + S_{AB} = S^2$ .

(2) The circumcenter, on the other hand, is the point

$$O = (a^2 S_A : b^2 S_B : c^2 S_C) = (S_A(S_B + S_C) : S_B(S_C + S_A) : S_C(S_A + S_B)).$$

Note that in this form, the coordinate sum is  $2(S_{AB} + S_{BC} + S_{CA}) = 2S^2$ .

### Exercises

1. Calculate the coordinates of the nine-point center in terms of  $S_A, S_B, S_C$ .<sup>17</sup>
2. Calculate the coordinates of the reflection of the orthocenter in the circumcenter, *i.e.*, the point  $L$  which divides the segment  $HO$  in the ratio  $HL : LO = 2 : -1$ . This is called the *de Longchamps point* of triangle  $ABC$ .<sup>18</sup>

### 3.4.2 Conway's formula

If the swing angles of a point  $P$  on the side  $BC$  are  $\angle CBP = \theta$  and  $\angle BCP = \varphi$ , the coordinates of  $P$  are

$$(-a^2 : S_C + S_\varphi : S_B + S_\theta).$$

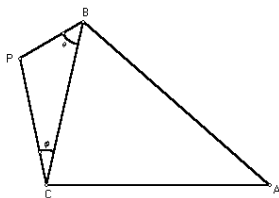

The swing angles are chosen in the range  $-\frac{\pi}{2} \leq \theta, \varphi \leq \frac{\pi}{2}$ . The angle  $\theta$  is positive or negative according as angles  $\angle CBP$  and  $\angle CBA$  have different or the same orientation.

<sup>17</sup> $N = (S^2 + S_{BC} : S^2 + S_{CA} : S^2 + S_{AB})$ .

<sup>18</sup> $L = (S_{CA} + S_{AB} - S_{BC} : \dots : \dots) = (\frac{1}{S_B} + \frac{1}{S_C} - \frac{1}{S_A} : \dots : \dots)$ . It appears in ETC as the point  $X_{20}$ .

### 3.4.3 Examples

#### Squares erected on the sides of a triangle

Consider the square  $BCX_1X_2$  erected externally on the side  $BC$  of triangle  $ABC$ . The swing angles of  $X_1$  with respect to the side  $BC$  are

$$\angle CBX_1 = \frac{\pi}{4}, \quad \angle BCX_1 = \frac{\pi}{2}.$$

Since  $\cot \frac{\pi}{4} = 1$  and  $\cot \frac{\pi}{2} = 0$ ,

$$X_1 = (-a^2 : S_C : S_B + S).$$

Similarly,

$$X_2 = (-a^2 : S_C + S : S_B).$$

#### Exercises

1. Find the midpoint of  $X_1X_2$ .
2. Find the vertices of the inscribed squares with a side along  $BC$ .<sup>19</sup>

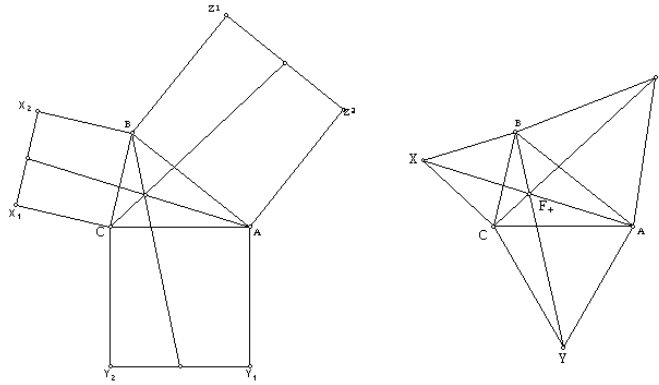

## 3.5 The Kiepert perspectors

### 3.5.1 The Fermat points

Consider the equilateral triangle  $BCX$  erected externally on the side  $BC$  of triangle  $ABC$ . The swing angles are  $\angle CBX = \angle BCX = \frac{\pi}{3}$ . Since

<sup>19</sup>Recall that this can be obtained from applying the homothety  $h(A, \frac{S}{S+a^2})$  to the square  $BCX_1X_2$

$$\cot \frac{\pi}{3} = \frac{1}{\sqrt{3}},$$

$$X = \left( -a^2 : S_C + \frac{S}{\sqrt{3}} : S_B + \frac{S}{\sqrt{3}} \right),$$

which can be rearranged in the form

$$X = \left( \frac{-a^2}{(S_B + \frac{S}{\sqrt{3}})(S_C + \frac{S}{\sqrt{3}})} : \frac{1}{S_B + \frac{S}{\sqrt{3}}} : \frac{1}{S_C + \frac{S}{\sqrt{3}}} \right).$$

Similarly, we write down the coordinates of the apexes  $Y, Z$  of the equilateral triangles  $CAY$  and  $ABZ$  erected externally on the other two sides. These are

$$Y = \left( \frac{1}{S_A + \frac{S}{\sqrt{3}}} : \text{*****} : \frac{1}{S_C + \frac{S}{\sqrt{3}}} \right)$$

and

$$Z = \left( \frac{1}{S_A + \frac{S}{\sqrt{3}}} : \frac{1}{S_B + \frac{S}{\sqrt{3}}} : \text{*****} \right).$$

Here we simply write  $\text{*****}$  in places where the exact values of the coordinates are not important. This is a particular case of the following general situation.

### 3.5.2 Perspective triangles

Suppose  $X, Y, Z$  are points whose coordinates can be written in the form

$$\begin{aligned} X &= \text{*****} : y : z, \\ Y &= x : \text{*****} : z, \\ Z &= x : y : \text{*****}. \end{aligned}$$

The lines  $AX, BY, CZ$  are concurrent at the point  $P = (x : y : z)$ .

*Proof.* The intersection of  $AX$  and  $BC$  is the trace of  $X$  on the side  $BC$ . It is the point  $(0 : y : z)$ . Similarly, the intersections  $BY \cap CA$  and  $CZ \cap AB$  are the points  $(x : 0 : z)$  and  $(x : y : 0)$ . These three points are in turn the traces of  $P = (x : y : z)$ . Q.E.D.

We say that triangle  $XYZ$  is *perspective* with  $ABC$ , and call the point  $P$  the *perspector* of  $XYZ$ .

We conclude therefore that *the apexes of the equilateral triangles erected externally on the sides of a triangle  $ABC$  form a triangle perspective with  $ABC$  at the point*

$$F_+ = \left( \frac{1}{\sqrt{3}S_A + S} : \frac{1}{\sqrt{3}S_B + S} : \frac{1}{\sqrt{3}S_C + S} \right).$$

This is called the (positive) *Fermat point* of triangle  $ABC$ .<sup>20</sup>

### Exercises

1. If the equilateral triangles are erected “internally” on the sides, the apexes again form a triangle with perspector

$$F_- = \left( \frac{1}{\sqrt{3}S_A - S} : \frac{1}{\sqrt{3}S_B - S} : \frac{1}{\sqrt{3}S_C - S} \right),$$

the negative Fermat point of triangle  $ABC$ .<sup>21</sup>

2. Given triangle  $ABC$ , extend the sides  $AC$  to  $B_a$  and  $AB$  to  $C_a$  such that  $CB_a = BC_a = a$ . Similarly define  $C_b, A_b, A_c$ , and  $B_c$ .
  - (a) Write down the coordinates of  $B_a$  and  $C_a$ , and the coordinates of the intersection  $A'$  of  $BB_a$  and  $CC_a$ .
  - (b) Similarly define  $B'$  and  $C'$ , and show that  $A'B'C'$  is perspective with  $ABC$ . Calculate the coordinates of the perspector.<sup>22</sup>

### 3.5.3 Isosceles triangles erected on the sides and Kiepert perspectors

More generally, consider an isosceles triangle  $YCA$  of base angle  $\angle YCA = \angle YAC = \theta$ . The vertex  $Y$  has coordinates

$$(S_C + S_\theta : -b^2 : S_A + S_\theta).$$

If *similar* isosceles triangles  $XBC$  and  $ZAB$  are erected on the other two sides (with the same orientation), the lines  $AX, BY$ , and  $CZ$  are concurrent at the point

$$K(\theta) = \left( \frac{1}{S_A + S_\theta} : \frac{1}{S_B + S_\theta} : \frac{1}{S_C + S_\theta} \right).$$

We call  $XYZ$  the Kiepert triangle and  $K(\theta)$  the *Kiepert perspector* of parameter  $\theta$ .

---

<sup>20</sup>The positive Fermat point is also known as the first isogonic center. It appears in ETC as the point  $X_{13}$ .

<sup>21</sup>The negative Fermat point is also known as the second isogonic center. It appears in ETC as the point  $X_{14}$ .

<sup>22</sup>The Spieker point.



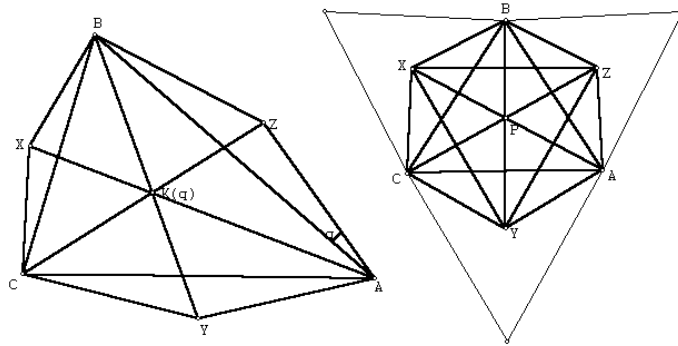

### 3.5.4 The Napoleon points

The famous Napoleon theorem states that *the centers of the equilateral triangles erected externally on the sides of a triangle form an equilateral triangle*. These centers are the apexes of similar isosceles triangles of base angle  $30^\circ$  erected externally on the sides. They give the Kiepert perspector

$$\left( \frac{1}{S_A + \sqrt{3}S} : \frac{1}{S_B + \sqrt{3}S} : \frac{1}{S_C + \sqrt{3}S} \right).$$

This is called the (positive) Napoleon point of the triangle.<sup>23</sup> Analogous results hold for equilateral triangles erected internally, leading to the negative Napoleon point<sup>24</sup>

$$\left( \frac{1}{S_A - \sqrt{3}S} : \frac{1}{S_B - \sqrt{3}S} : \frac{1}{S_C - \sqrt{3}S} \right).$$

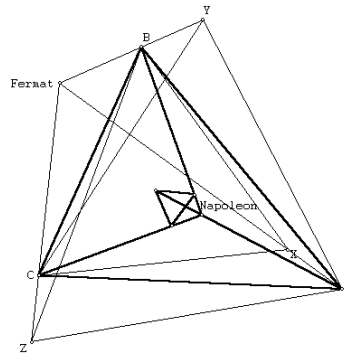

<sup>23</sup>The positive Napoleon point appears in ETC as the point  $X_{17}$ .

<sup>24</sup>The negative Napoleon point appears in ETC as the point  $X_{18}$ .

## Exercises

- The centers of the three squares erected externally on the sides of triangle  $ABC$  form a triangle perspective with  $ABC$ . The perspector is called the (positive) Vecten point. Why is this a Kiepert perspector? Identify its Kiepert parameter, and write down its coordinates? <sup>25</sup>
- Let  $ABC$  be a given triangle. Construct a small semicircle with  $B$  as center and a diameter perpendicular to  $BC$ , intersecting the side  $BC$ . **Animate** a point  $T$  on this semicircle, and **hide** the semicircle.
  - Construct the ray  $BT$  and let it intersect the perpendicular bisector of  $BC$  at  $X$ .
  - Reflect** the ray  $BT$  in the **bisector** of angle  $B$ , and construct the perpendicular bisector of  $AB$  to intersect this reflection at  $Z$ .
  - Reflect**  $AZ$  in the **bisector** of angle  $A$ , and **reflect**  $CX$  in the **bisector** of angle  $C$ . Label the intersection of these two reflections  $Y$ .
  - Construct the perspector  $P$  of the triangle  $XYZ$ .
  - What is the **locus** of  $P$  as  $T$  traverses the semicircle?
- Calculate the coordinates of the midpoint of the segment  $F_+F_-$ . <sup>26</sup>
- Inside triangle  $ABC$ , consider two congruent circles  $I_{ab}(r_1)$  and  $I_{ac}(r_1)$  tangent to each other (externally), both to the side  $BC$ , and to  $CA$  and  $AB$  respectively. Note that the centers  $I_{ab}$  and  $I_{ac}$ , together with their pedals on  $BC$ , form a rectangle of sides  $2 : 1$ . This rectangle can be constructed as the image under the homothety  $h(I, \frac{2r}{a})$  of a similar rectangle erected externally on the side  $BC$ .

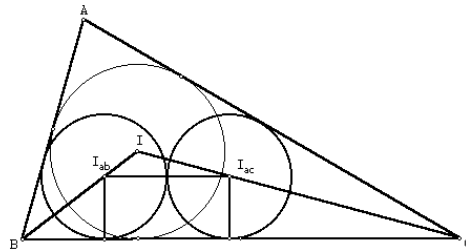

<sup>25</sup>This is  $K(\frac{\pi}{4})$ , the positive Vecten point. It appears in ETC as  $X_{485}$ .

<sup>26</sup> $((b^2 - c^2)^2 : (c^2 - a^2)^2 : (a^2 - b^2)^2)$ . This point appears in ETC as  $X_{115}$ . It lies on the nine-point circle.

- (a) Make use of these to construct the two circles.
- (b) Calculate the homogeneous barycentric coordinates of the point of tangency of the two circles.<sup>27</sup>
- (c) Similarly, there are two other pairs of congruent circles on the sides  $CA$  and  $AB$ . The points of tangency of the three pairs have a perspector<sup>28</sup>

$$\left( \frac{1}{bc+S} : \frac{1}{ca+S} : \frac{1}{ab+S} \right).$$

- (d) Show that the pedals of the points of tangency on the respective side lines of  $ABC$  are the traces of<sup>29</sup>

$$\left( \frac{1}{bc+S+S_A} : \frac{1}{ca+S+S_B} : \frac{1}{ab+S+S_C} \right).$$

### 3.5.5 Nagel's Theorem

Suppose  $X, Y, Z$  are such that

$$\begin{aligned} \angle CAY &= \angle BAZ = \theta, \\ \angle ABZ &= \angle CBX = \varphi, \\ \angle BCX &= \angle ACY = \psi. \end{aligned}$$

The lines  $AX, BY, CZ$  are concurrent at the point

$$\left( \frac{1}{S_A + S_\theta} : \frac{1}{S_B + S_\varphi} : \frac{1}{S_C + S_\psi} \right).$$

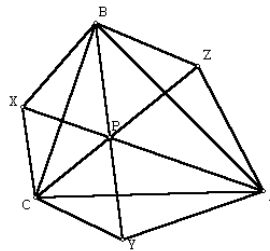

<sup>27</sup>This divides  $ID$  ( $D =$  midpoint of  $BC$ ) in the ratio  $2r : a$  and has coordinates  $(a^2 : ab + S : ac + S)$ .

<sup>28</sup>This point is not in the current edition of ETC.

<sup>29</sup>This point is not in the current edition of ETC.

**Exercises**

1. Let  $X', Y', Z'$  be respectively the pedals of  $X$  on  $BC$ ,  $Y$  on  $CA$ , and  $Z$  on  $AB$ . Show that  $X'Y'Z'$  is a cevian triangle. <sup>30</sup>
2. For  $i = 1, 2$ , let  $X_iY_iZ_i$  be the triangle formed with given angles  $\theta_i, \varphi_i$  and  $\psi_i$ . Show that the intersections

$$X = X_1X_2 \cap BC, \quad Y = Y_1Y_2 \cap CA, \quad Z = Z_1Z_2 \cap AB$$

form a cevian triangle. <sup>31</sup>

---

<sup>30</sup>Floor van Lamoen.

<sup>31</sup>Floor van Lamoen.  $X = (0 : S_{\psi_1} - S_{\psi_2} : S_{\varphi_1} - S_{\varphi_2})$ .

# Chapter 4

## Straight Lines

### 4.1 The equation of a line

#### 4.1.1 Two-point form

The equation of the line joining two points with coordinates  $(x_1 : y_1 : z_1)$  and  $(x_2 : y_2 : z_2)$  is

$$\begin{vmatrix} x_1 & y_1 & z_1 \\ x_2 & y_2 & z_2 \\ x & y & z \end{vmatrix} = 0,$$

or

$$(y_1 z_2 - y_2 z_1)x + (z_1 x_2 - z_2 x_1)y + (x_1 y_2 - x_2 y_1)z = 0.$$

#### 4.1.2 Examples

1. The equations of the side lines  $BC$ ,  $CA$ ,  $AB$  are respectively  $x = 0$ ,  $y = 0$ ,  $z = 0$ .
2. The perpendicular bisector of  $BC$  is the line joining the circumcenter  $O = (a^2 S_A : b^2 S_B : c^2 S_C)$  to the midpoint of  $BC$ , which has coordinates  $(0 : 1 : 1)$ . By the two point form, it has equation

$$(b^2 S_B - c^2 S_C)x - a^2 S_A y + a^2 S_A z = 0,$$

Since  $b^2 S_B - c^2 S_C = \dots = S_A(S_B - S_C) = -S_A(b^2 - c^2)$ , this equation can be rewritten as

$$(b^2 - c^2)x + a^2(y - z) = 0.$$

3. The equation of the Euler line, as the line joining the centroid  $(1 : 1 : 1)$  to the orthocenter  $(S_{BC} : S_{CA} : S_{AB})$  is

$$(S_{AB} - S_{CA})x + (S_{BC} - S_{AB})y + (S_{CA} - S_{BC})z = 0,$$

or

$$\sum_{\text{cyclic}} S_A(S_B - S_C)x = 0.$$

4. The equation of the  $OI$ -line joining the circumcenter  $(a^2S_A : b^2S_B : c^2S_C)$  to and the incenter  $(a : b : c)$  is

$$0 = \sum_{\text{cyclic}} (b^2S_{BC} - c^2S_Cb)x = \sum_{\text{cyclic}} bc(bS_B - cS_C)x.$$

Since  $bS_B - cS_C = \dots = -2(b - c)s(s - a)$  (exercise), this equation can be rewritten as

$$\sum_{\text{cyclic}} bc(b - c)s(s - a)x = 0.$$

or

$$\sum_{\text{cyclic}} \frac{(b - c)(s - a)}{a}x = 0.$$

5. The line joining the two Fermat points

$$\begin{aligned} F_{\pm} &= \left( \frac{1}{\sqrt{3}S_A \pm S} : \frac{1}{\sqrt{3}S_B \pm S} : \frac{1}{\sqrt{3}S_C \pm S} \right) \\ &= ((\sqrt{3}S_B \pm S)(\sqrt{3}S_C \pm S) : \dots : \dots) \end{aligned}$$

has equation

$$\begin{aligned} 0 &= \sum_{\text{cyclic}} \left( \frac{1}{(\sqrt{3}S_B + S)(\sqrt{3}S_C - S)} - \frac{1}{(\sqrt{3}S_B - S)(\sqrt{3}S_C + S)} \right) x \\ &= \sum_{\text{cyclic}} \left( \frac{(\sqrt{3}S_B - S)(\sqrt{3}S_C + S) - (\sqrt{3}S_B + S)(\sqrt{3}S_C - S)}{(3S_{BB} - S^2)(3S_{CC} - S^2)} \right) x \\ &= \sum_{\text{cyclic}} \left( \frac{2\sqrt{3}(S_B - S_C)S}{(3S_{BB} - S^2)(3S_{CC} - S^2)} \right) x. \end{aligned}$$

Clearing denominators, we obtain

$$\sum_{\text{cyclic}} (S_B - S_C)(3S_{AA} - S^2)x = 0.$$

### 4.1.3 Intercept form: tripole and tripolar

If the intersections of a line  $\mathcal{L}$  with the side lines are

$$X = (0 : v : -w), \quad Y = (-u : 0 : w), \quad Z = (u : -v : 0),$$

the equation of the line  $\mathcal{L}$  is

$$\frac{x}{u} + \frac{y}{v} + \frac{z}{w} = 0.$$

We shall call the point  $P = (u : v : w)$  the *tripole* of  $\mathcal{L}$ , and the line  $\mathcal{L}$  the *tripolar* of  $P$ .

#### Construction of tripole

Given a line  $\mathcal{L}$  intersecting  $BC$ ,  $CA$ ,  $AB$  at  $X$ ,  $Y$ ,  $Z$  respectively, let

$$A' = BY \cap CZ, \quad B' = CZ \cap AX, \quad C' = AX \cap BY.$$

The lines  $AA'$ ,  $BB'$  and  $CC'$  intersect at the tripole  $P$  of  $\mathcal{L}$ .

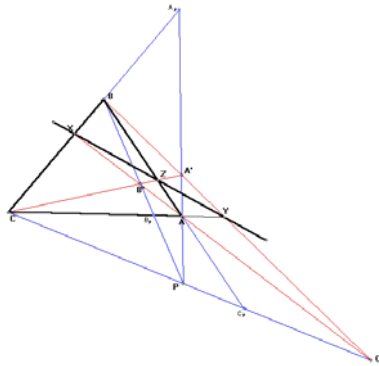

#### Construction of tripolar

Given  $P$  with traces  $A_P$ ,  $B_P$ , and  $C_P$  on the side lines, let

$$X = B_P C_P \cap BC, \quad Y = C_P A_P \cap CA, \quad Z = A_P B_P \cap AB.$$

These points  $X$ ,  $Y$ ,  $Z$  lie on the tripolar of  $P$ .

**Exercises**

1. Find the equation of the line joining the centroid to a given point  $P = (u : v : w)$ .<sup>1</sup>
2. Find the equations of the cevians of a point  $P = (u : v : w)$ .
3. Find the equations of the angle bisectors.

**4.2 Infinite points and parallel lines****4.2.1 The infinite point of a line**

The infinite point of a line  $\mathcal{L}$  has homogeneous coordinates given by the difference of the *absolute* barycentric coordinates of two distinct points on the line. As such, the coordinate sum of an infinite point is zero. We think of all infinite points constituting the line at infinity,  $\mathcal{L}_\infty$ , which has equation  $x + y + z = 0$ .

**Examples**

1. The infinite points of the side lines  $BC$ ,  $CA$ ,  $AB$  are  $(0 : -1 : 1)$ ,  $(1 : 0 : -1)$ ,  $(-1 : 1 : 0)$  respectively.
2. The infinite point of the  $A$ -altitude has homogeneous coordinates

$$(0 : S_C : S_B) - a^2(1 : 0 : 0) = (-a^2 : S_C : S_B).$$

3. More generally, the infinite point of the line  $px + qy + rz = 0$  is

$$(q - r : r - p : p - q).$$

4. The infinite point of the Euler line is the point

$$3(S_{BC} : S_{CA} : S_{AB}) - SS(1 : 1 : 1) \sim (3S_{BC} - SS : 3S_{CA} - SS : 3S_{AB} - SS).$$

5. The infinite point of the  $OI$ -line is

$$\begin{aligned} & (ca(c - a)(s - b) - ab(a - b)(s - c) : \dots : \dots) \\ \sim & (a(a^2(b + c) - 2abc - (b + c)(b - c)^2) : \dots : \dots). \end{aligned}$$

---

<sup>1</sup>Equation:  $(v - w)x + (w - u)y + (u - v)z = 0$ .



### 4.2.2 Parallel lines

Parallel lines have the same infinite point. The line through  $P = (u : v : w)$  parallel to  $\mathcal{L} : px + qy + rz = 0$  has equation

$$\begin{vmatrix} q - r & r - p & p - q \\ u & v & w \\ x & y & z \end{vmatrix} = 0.$$

#### Exercises

1. Find the equations of the lines through  $P = (u : v : w)$  parallel to the side lines.
2. Let  $DEF$  be the medial triangle of  $ABC$ , and  $P$  a point with cevian triangle  $XYZ$  (with respect to  $ABC$ ). Find  $P$  such that the lines  $DX$ ,  $EY$ ,  $FZ$  are parallel to the internal bisectors of angles  $A$ ,  $B$ ,  $C$  respectively.<sup>2</sup>

### 4.3 Intersection of two lines

The intersection of the two lines

$$\begin{aligned} p_1x + q_1y + r_1z &= 0, \\ p_2x + q_2y + r_2z &= 0 \end{aligned}$$

is the point

$$(q_1r_2 - q_2r_1 : r_1p_2 - r_2p_1 : p_1q_2 - p_2q_1).$$

The infinite point of a line  $\mathcal{L}$  can be regarded as the intersection of  $\mathcal{L}$  with the line at infinity  $\mathcal{L}_\infty : x + y + z = 0$ .

#### Theorem

Three lines  $p_ix + q_iy + r_iz = 0$ ,  $i = 1, 2, 3$ , are concurrent if and only if

$$\begin{vmatrix} p_1 & q_1 & r_1 \\ p_2 & q_2 & r_2 \\ p_3 & q_3 & r_3 \end{vmatrix} = 0.$$

---

<sup>2</sup>The Nagel point  $P = (b + c - a : c + a - b : a + b - c)$ . N.Dergiades, Hyacinthos, message 3677, 8/31/01.

### 4.3.1 Intersection of the Euler and Fermat lines

Recall that these lines have equations

$$\sum_{\text{cyclic}} S_A(S_B - S_C)x = 0,$$

and

$$\sum_{\text{cyclic}} (S_B - S_C)(3S_{AA} - S^2)x = 0.$$

The  $A$ -coordinate of their intersection

$$\begin{aligned} &= S_B(S_C - S_A)(S_A - S_B)(3S_{CC} - S^2) \\ &\quad - S_C(S_A - S_B)(S_C - S_A)(3S_{BB} - S^2) \\ &= (S_C - S_A)(S_A - S_B)[S_B(3S_{CC} - S^2) - S_C(3S_{BB} - S^2)] \\ &= (S_C - S_A)(S_A - S_B)[3S_{BC}(S_C - S_B) - S^2(S_B - S_C)] \\ &= -(S_B - S_C)(S_C - S_A)(S_A - S_B)(3S_{BC} + S^2). \end{aligned}$$

This intersection is the point

$$(3S_{BC} + S^2 : 3S_{CA} + S^2 : 3S_{AB} + S^2).$$

Since  $(3S_{BC} : 3S_{CA} : 3S_{AB})$  and  $(S^2 : S^2 : S^2)$  represent  $H$  and  $G$ , with equal coordinate sums, this point is the midpoint of  $GH$ .<sup>3</sup>

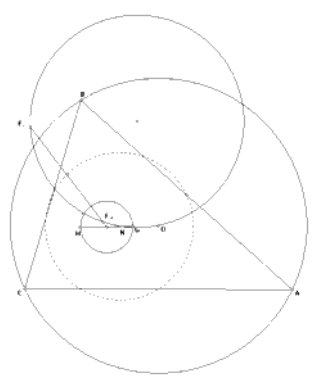

#### Remark

Lester has discovered that there is a circle passing the two Fermat points, the circumcenter, and the nine-point center.<sup>4</sup> The circle with  $GH$  as diameter,

<sup>3</sup>This point appears in ETC as  $X_{381}$ .

<sup>4</sup>J.A. Lester, Triangles, III: complex centre functions and Ceva's theorem, *Aequationes Math.*, 53 (1997) 4–35.

whose center is the intersection of the Fermat and Euler line as we have shown above, is orthogonal to the Lester circle.<sup>5</sup> It is also interesting to note that the midpoint between the Fermat points is a point on the nine-point circle. It has coordinates  $((b^2 - c^2)^2 : (c^2 - a^2)^2 : (a^2 - b^2)^2)$ .

### 4.3.2 Triangle bounded by the outer side lines of the squares erected externally

Consider the square  $BCX_1X_2$  erected externally on  $BC$ . Since  $X_1 = (-a^2 : S_C : S_B + S)$ , and the line  $X_1X_2$ , being parallel to  $BC$ , has infinite point  $(0 : -1 : 1)$ , this line has equation

$$(S_C + S_B + S)x + a^2y + a^2z = 0.$$

Since  $S_B + S_C = a^2$ , this can be rewritten as

$$a^2(x + y + z) + Sx = 0.$$

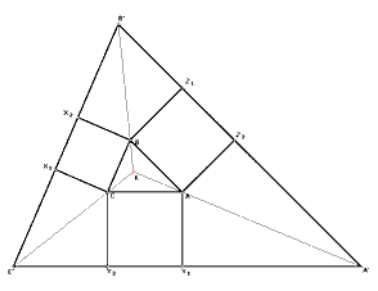

Similarly, if  $CAY_1Y_2$  and  $ABZ_1Z_2$  are squares erected externally on the other two sides, the lines  $Y_1Y_2$  and  $Z_1Z_2$  have equations

$$b^2(x + y + z) + Sy = 0$$

and

$$c^2(x + y + z) + Sz = 0$$

respectively. These two latter lines intersect at the point

$$X = -(b^2 + c^2 + S) : b^2 : c^2).$$

Similarly, the lines  $Z_1Z_2$  and  $X_1X_2$  intersect at

$$Y = (a^2 : -(c^2 + a^2 + S) : c^2),$$

<sup>5</sup>P. Yiu, Hyacinthos, message 1258, August 21, 2000.

and the lines  $X_1X_2$  and  $Y_1Y_2$  intersect at

$$Z = (a^2 : b^2 : -(a^2 + b^2 + S)).$$

The triangle  $XYZ$  is perspective with  $ABC$ , at the point

$$K = (a^2 : b^2 : c^2).$$

This is called the *symmedian point* of triangle  $ABC$ .<sup>6</sup>

### Exercises

1. The symmedian point lies on the line joining the Fermat points.
2. The line joining the two Kiepert perspectors  $K(\pm\theta)$  has equation

$$\sum_{\text{cyclic}} (S_B - S_C)(S_{AA} - S^2 \cot^2 \theta)x = 0.$$

Show that this line passes through a fixed point.<sup>7</sup>

3. Show that triangle  $A^\theta B^\theta C^\theta$  has the same centroid as triangle  $ABC$ .
4. Construct the parallels to the side lines through the symmedian point. The 6 intersections on the side lines lie on a circle. The symmedian point is the unique point with this property.<sup>8</sup>
5. Let  $DEF$  be the medial triangle of  $ABC$ . Find the equation of the line joining  $D$  to the excenter  $I_a = (-a : b : c)$ . Similarly write down the equation of the lines joining to  $E$  to  $I_b$  and  $F$  to  $I_c$ . Show that these three lines are concurrent by working out the coordinates of their common point.<sup>9</sup>
6. The perpendiculars from the excenters to the corresponding sides are concurrent. Find the coordinates of the intersection by noting how it is related to the circumcenter and the incenter.<sup>10</sup>

<sup>6</sup>It is also known as the Grebe point, and appears in ETC as the point  $X_6$ .

<sup>7</sup>The symmedian point.

<sup>8</sup>This was first discovered by Lemoine in 1883.

<sup>9</sup>This is the Mittenpunkt  $(a(s-a) : \dots : \dots)$ .

<sup>10</sup>This is the reflection of  $I$  in  $O$ . As such, it is the point  $2O - I$ , and has coordinates

$$(a(a^3 + a^2(b+c) - a(b+c)^2 - (b+c)(b-c)^2) : \dots : \dots).$$

7. Let  $D, E, F$  be the midpoints of the sides  $BC, CA, AB$  of triangle  $ABC$ . For a point  $P$  with traces  $A_P, B_P, C_P$ , let  $X, Y, Z$  be the midpoints of  $B_P C_P, C_P A_P, A_P B_P$  respectively. Find the equations of the lines  $DX, EY, FZ$ , and show that they are concurrent. What are the coordinates of their intersection? <sup>11</sup>
8. Let  $D, E, F$  be the midpoints of the sides of  $BC, CA, AB$  of triangle  $ABC$ , and  $X, Y, Z$  the midpoints of the altitudes from  $A, B, C$  respectively. Find the equations of the lines  $DX, EY, FZ$ , and show that they are concurrent. What are the coordinates of their intersection? <sup>12</sup>
9. Given triangle  $ABC$ , extend the sides  $AC$  to  $B_a$  and  $AB$  to  $C_a$  such that  $CB_a = BC_a = a$ . Similarly define  $C_b, A_b, A_c$ , and  $B_c$ . The lines  $B_c C_b, C_b A_b$ , and  $A_c B_c$  bound a triangle perspective with  $ABC$ . Calculate the coordinate of the perspector. <sup>13</sup>

#### 4.4 Pedal triangle

The pedals of a point  $P = (u : v : w)$  are the intersections of the side lines with the corresponding perpendiculars through  $P$ . The  $A$ -altitude has infinite point  $A_H - A = (0 : S_C : S_B) - (S_B + S_C : 0 : 0) = (-a^2 : S_C : S_B)$ . The perpendicular through  $P$  to  $BC$  is the line

$$\begin{vmatrix} -a^2 & S_C & S_B \\ u & v & w \\ x & y & z \end{vmatrix} = 0,$$

or

$$-(S_B v - S_C w)x + (S_B u + a^2 w)y - (S_C u + a^2 v)z = 0.$$

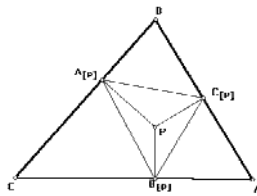

<sup>11</sup>The intersection is the point dividing the segment  $PG$  in the ratio  $3 : 1$ .

<sup>12</sup>This intersection is the symmedian point  $K = (a^2 : b^2 : c^2)$ .

<sup>13</sup> $(\frac{a(b+c)}{b+c-a} : \dots : \dots)$ . This appears in ETC as  $X_{65}$ .

This intersects  $BC$  at the point

$$A_{[P]} = (0 : S_C u + a^2 v : S_B u + a^2 w).$$

Similarly the coordinates of the pedals on  $CA$  and  $AB$  can be written down. The triangle  $A_{[P]}B_{[P]}C_{[P]}$  is called the *pedal triangle* of triangle  $ABC$ :

$$\begin{pmatrix} A_{[P]} \\ B_{[P]} \\ C_{[P]} \end{pmatrix} = \begin{pmatrix} 0 & S_C u + a^2 v & S_B u + a^2 w \\ S_C v + b^2 u & 0 & S_A v + b^2 w \\ S_B w + c^2 u & S_A w + c^2 v & 0 \end{pmatrix}$$

#### 4.4.1 Examples

1. The pedal triangle of the circumcenter is clearly the medial triangle.
2. The pedal triangle of the orthocenter is called the *orthic* triangle. Its vertices are clearly the traces of  $H$ , namely, the points  $(0 : S_C : S_B)$ ,  $(S_C : 0 : S_A)$ , and  $(S_B : S_A : 0)$ .
3. Let  $L$  be the reflection of the orthocenter  $H$  in the circumcenter  $O$ . This is called the de Longchamps point.<sup>14</sup> Show that the pedal triangle of  $L$  is the cevian triangle of some point  $P$ . What are the coordinates of  $P$ ?<sup>15</sup>

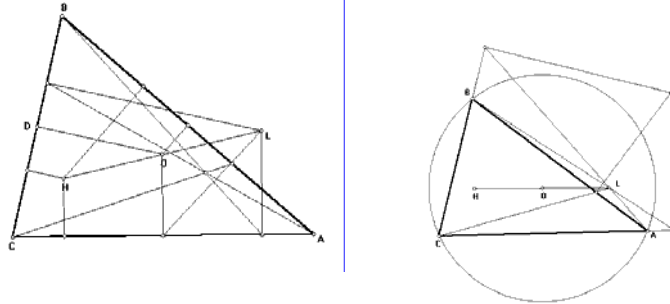

4. Let  $L$  be the de Longchamps point again, with homogeneous barycentric coordinates

$$(S_{CA} + S_{AB} - S_{BC} : S_{AB} + S_{BC} - S_{CA} : S_{BC} + S_{CA} - S_{AB}).$$

Find the equations of the perpendiculars to the side lines at the corresponding traces of  $L$ . Show that these are concurrent, and find the coordinates of the intersection.

<sup>14</sup>The de Longchamps point appears as  $X_{20}$  in ETC.

<sup>15</sup> $P = (S_A : S_B : S_C)$  is the isotomic conjugate of the orthocenter. It appears in ETC as the point  $X_{69}$ .

The perpendicular to  $BC$  at  $A_L = (0 : S_{AB} + S_{BC} - S_{CA} : S_{BC} + S_{CA} - S_{AB})$  is the line

$$\begin{vmatrix} -(S_B + S_C) & S_C & S_B \\ 0 & S_{AB} + S_{BC} - S_{CA} & S_{BC} + S_{CA} - S_{AB} \\ x & y & z \end{vmatrix} = 0.$$

This is

$$S^2(S_B - S_C)x - a^2(S_{BC} + S_{CA} - S_{AB})y + a^2(S_{BC} - S_{CA} + S_{AB})z = 0.$$

Similarly, we write down the equations of the perpendiculars at the other two traces. The three perpendiculars intersect at the point <sup>16</sup>

$$(a^2(S_C^2 S_A^2 + S_A^2 S_B^2 - S_B^2 S_C^2) : \dots : \dots).$$

### Exercises

1. Let  $D, E, F$  be the midpoints of the sides  $BC, CA, AB$ , and  $A', B', C'$  the pedals of  $A, B, C$  on their opposite sides. Show that  $X = EC' \cap FB', Y = FA' \cap DC',$  and  $Z = DB' \cap EC'$  are collinear. <sup>17</sup>
2. Let  $X$  be the pedal of  $A$  on the side  $BC$  of triangle  $ABC$ . Complete the squares  $AXX_bA_b$  and  $AXX_cA_c$  with  $X_b$  and  $X_c$  on the line  $BC$ . <sup>18</sup>
  - (a) Calculate the coordinates of  $A_b$  and  $A_c$ . <sup>19</sup>
  - (b) Calculate the coordinates of  $A' = BA_c \cap CA_b$ . <sup>20</sup>
  - (c) Similarly define  $B'$  and  $C'$ . Triangle  $A'B'C'$  is perspective with  $ABC$ . What is the perspector? <sup>21</sup>
  - (d) Let  $A''$  be the pedal of  $A'$  on the side  $BC$ . Similarly define  $B''$  and  $C''$ . Show that  $A''B''C''$  is perspective with  $ABC$  by calculating the coordinates of the perspector. <sup>22</sup>

<sup>16</sup>This point appears in ETC as  $X_{1078}$ . Conway calls this point the *logarithm of the de Longchamps point*.

<sup>17</sup>These are all on the Euler line. See G. Leversha, Problem 2358 and solution, *Cruce Mathematicorum*, 24 (1998) 303; 25 (1999) 371–372.

<sup>18</sup>A.P. Hatzipolakis, Hyacinthos, message 3370, 8/7/01.

<sup>19</sup> $A_b = (a^2 : -S : S)$  and  $A_c = (a^2 : S : -S)$ .

<sup>20</sup> $A' = (a^2 : S : S)$ .

<sup>21</sup>The centroid.

<sup>22</sup> $(\frac{1}{S_A+S} : \frac{1}{S_B+S} : \frac{1}{S_C+S})$ .

## 4.5 Perpendicular lines

Given a line  $\mathcal{L} : px + qy + rz = 0$ , we determine the infinite point of lines perpendicular to it.<sup>23</sup> The line  $\mathcal{L}$  intersects the side lines  $CA$  and  $AB$  at the points  $Y = (-r : 0 : p)$  and  $Z = (q : -p : 0)$ . To find the perpendicular from  $A$  to  $\mathcal{L}$ , we first find the equations of the perpendiculars from  $Y$  to  $AB$  and from  $Z$  to  $CA$ . These are

$$\begin{vmatrix} S_B & S_A & -c^2 \\ -r & 0 & p \\ x & y & z \end{vmatrix} = 0 \quad \text{and} \quad \begin{vmatrix} S_C & -b^2 & S_A \\ q & -p & 0 \\ x & y & z \end{vmatrix} = 0$$

These are

$$\begin{aligned} S_{AP}x + (c^2r - S_Bp)y + S_{Ar}z &= 0, \\ S_{AP}x + S_{Aq}y + (b^2q - S_Cp)z &= 0. \end{aligned}$$

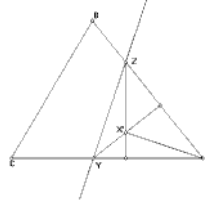

These two perpendiculars intersect at the orthocenter of triangle  $AYZ$ , which is the point

$$\begin{aligned} X' &= (**** : S_{Ap}(S_{Ar} - b^2q + S_Cp) : S_{Ap}(S_{Aq} + S_Bp - c^2r) \\ &\sim (**** : S_C(p - q) - S_A(q - r) : S_A(q - r) - S_B(r - p)). \end{aligned}$$

The perpendicular from  $A$  to  $\mathcal{L}$  is the line  $AX'$ , which has equation

$$\begin{vmatrix} 1 & 0 & 0 \\ *** & S_C(p - q) - S_A(q - r) & -S_A(q - r) + S_B(r - p) \\ x & y & z \end{vmatrix} = 0,$$

or

$$-(S_A(q - r) - S_B(r - p))y + (S_C(p - q) - S_A(q - r))z = 0.$$

This has infinite point

$$(S_B(r - p) - S_C(p - q) : S_C(p - q) - S_A(q - r) : S_A(q - r) - S_B(r - p)).$$

Note that the infinite point of  $\mathcal{L}$  is  $(q - r : r - p : p - q)$ . We summarize this in the following theorem.

<sup>23</sup>I learned of this method from Floor van Lamoen.



**Theorem**

If a line  $\mathcal{L}$  has infinite point  $(f : g : h)$ , the lines perpendicular to  $\mathcal{L}$  have infinite points

$$(f' : g' : h') = (S_Bg - S_Ch : S_Ch - S_Af : S_Af - S_Bg).$$

Equivalently, two lines with infinite points  $(f : g : h)$  and  $(f' : g' : h')$  are perpendicular to each other if and only if

$$S_Aff' + S_Bgg' + S_Chh' = 0.$$

**4.5.1 The tangential triangle**

Consider the tangents to the circumcircle at the vertices. The radius  $OA$  has infinite point

$$(a^2S_A : b^2S_B : c^2S_C) - (2S^2 : 0 : 0) = (-(b^2S_B + c^2S_C) : b^2S_B : c^2S_C).$$

The infinite point of the tangent at  $A$  is

$$(b^2S_{BB} - c^2S_{CC} : c^2S_{CC} + S_A(b^2S_B + c^2S_C) : -S_A(b^2S_B + c^2S_C) - b^2S_{BB}).$$

Consider the  $B$ -coordinate:

$$c^2S_{CC} + S_A(b^2S_B + c^2S_C) = c^2S_C(S_C + S_A) + b^2S_{AB} = b^2(c^2S_C + S_{AB}) = b^2S^2.$$

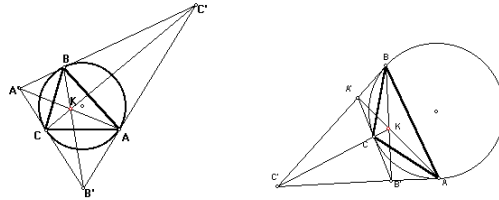

Similarly, the  $C$ -coordinate  $= -c^2S^2$ . It follows that this infinite point is  $(-(b^2 - c^2) : b^2 : -c^2)$ , and the tangent at  $A$  is the line

$$\begin{vmatrix} 1 & 0 & 0 \\ -(b^2 - c^2) & b^2 & -c^2 \\ x & y & z \end{vmatrix} = 0,$$

or simply  $c^2y + b^2z = 0$ . The other two tangents are  $c^2x + a^2z = 0$ , and  $b^2x + a^2y = 0$ . These three tangents bound a triangle with vertices

$$A' = (0 : b^2 : c^2), \quad B' = (a^2 : 0 : c^2), \quad C' = (a^2 : b^2 : 0).$$

This is called the *tangential triangle* of  $ABC$ . It is perspective with  $ABC$  at the point  $(a^2 : b^2 : c^2)$ , the symmedian point.

### 4.5.2 Line of ortho-intercepts <sup>24</sup>

Let  $P = (u : v : w)$ . We consider the line perpendicular to  $AP$  at  $P$ . Since the line  $AP$  has equation  $wy - vz = 0$  and infinite point  $(-(v+w) : v : w)$ , the perpendicular has infinite point  $(S_Bv - S_Cw : S_Cw + S_A(v+w) : -S_A(v+w) - S_Bv) \sim (S_Bv - S_Cw : S_Av + b^2w : -S_Aw - c^2v)$ . It is the line

$$\begin{vmatrix} u & v & w \\ S_Bv - S_Cw & S_Av + b^2w & -S_Aw - c^2v \\ x & y & z \end{vmatrix} = 0.$$

This perpendicular line intersects the side line  $BC$  at the point

$$\begin{aligned} & (0 : u(S_Av + b^2w) - v(S_Bv - S_Cw) : -u(S_Aw + c^2v) - w(S_Bv - S_Cw)) \\ & \sim (0 : (S_Au - S_Bv + S_Cw)v + b^2wu : -((S_Au + S_Bv - S_Cw)w + c^2uw)). \end{aligned}$$

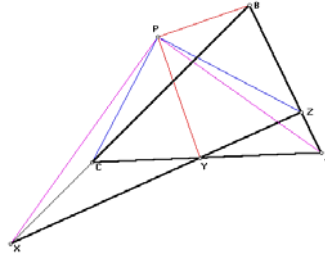

Similarly, the line perpendicular to  $BP$  at  $P$  intersects  $CA$  at

$$(-(-S_Au + S_Bv + S_Cw)u + a^2vw) : 0 : (S_Au - S_Bv + S_Cw)w + c^2uw$$

and

$$((-S_Au + S_Bv + S_Cw)u + a^2vw) : -(S_Au - S_Bv + S_Cw)v + b^2wu : 0).$$

These three points are collinear. The line containing them has equation

$$\sum_{\text{cyclic}} \frac{x}{(-S_Au + S_Bv + S_Cw)u + a^2vw} = 0.$$

### Exercises

1. If triangle  $ABC$  is acute-angled, the symmedian point is the Gergonne point of the tangential triangle.
2. Given a line  $\mathcal{L}$ , construct the two points each having  $\mathcal{L}$  as its line of ortho-intercepts. <sup>25</sup>

<sup>24</sup>B. Gibert, Hyacinthos, message 1158, August 5, 2000.

<sup>25</sup>One of these points lies on the circumcircle, and the other on the nine-point circle.

3. The tripole of the line of ortho-intercepts of the incenter is the point  $(\frac{a}{s-a} : \frac{b}{s-b} : \frac{c}{s-c})$ .<sup>26</sup>
4. Calculate the coordinates of the tripole of the line of ortho-intercepts of the nine-point center.<sup>27</sup>
5. Consider a line  $\mathcal{L} : px + qy + rz = 0$ .
  - (1) Calculate the coordinates of the pedals of  $A, B, C$  on the line  $\mathcal{L}$ . Label these points  $X, Y, Z$ .
  - (2) Find the equations of the perpendiculars from  $X, Y, Z$  to the corresponding side lines.
  - (3) Show that these three perpendiculars are concurrent, and determine the coordinates of the common point.

This is called the *orthopole* of  $\mathcal{L}$ .

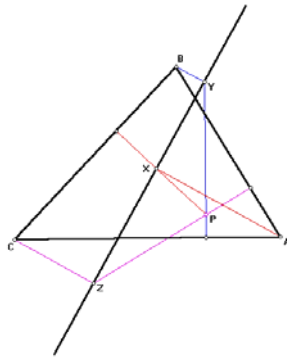

6. **Animate** a point  $P$  on the circumcircle. Construct the orthopole of the diameter  $OP$ . This orthopole lies on the nine-point circle.
7. Consider triangle  $ABC$  with its incircle  $I(r)$ .
  - (a) Construct a circle  $X_b(\rho_b)$  tangent to  $BC$  at  $B$ , and also externally to the incircle.
  - (b) Show that the radius of the circle ( $X_b$ ) is  $\rho_b = \frac{(-sb)^2}{4r}$ .
  - (c) Let  $X_c(\rho_c)$  be the circle tangent to  $BC$  at  $C$ , and also externally to the incircle. Calculate the coordinates of the pedal  $A'$  of the intersection  $BX_c \cap CX_b$  on the line  $BC$ .<sup>28</sup>

<sup>26</sup>This is a point on the  $OI$ -line of triangle  $ABC$ . It appears in ETC as  $X_{57}$ . This point divides  $OI$  in the ratio  $OX_{57} : OI = 2R + r : 2R - r$ .

<sup>27</sup> $(a^2(3S^2 - S_{AA}) : \dots : \dots)$ . This point is not in the current edition of ETC.

<sup>28</sup> $(0 : (s - c)^2 : (s - b)^2)$ .

- (d) Define  $B'$  and  $C'$ . Show that  $A'B'C'$  is perspective with  $ABC$  and find the perspector.<sup>29</sup>

## 4.6 Appendices

### 4.6.1 The excentral triangle

The vertices of the excentral triangle of  $ABC$  are the excenters  $I_a, I_b, I_c$ .

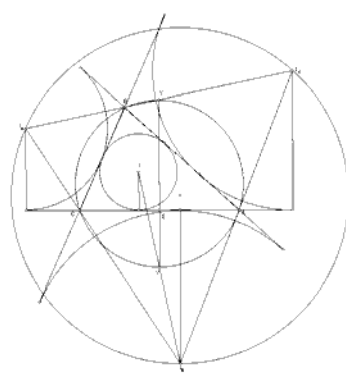

- (1) Identify the following elements of the excentral triangle in terms of the elements of triangle  $ABC$ .

Excentral triangle $I_a I_b I_c$	Triangle $ABC$
Orthocenter	$I$
Orthic triangle	Triangle $ABC$
Nine-point circle	Circumcircle
Euler line	$OI$ -line
Circumradius	$2R$
Circumcenter	$I' = \text{Reflection of } I \text{ in } O$
Centroid	centroid of $I' I N_a$ <sup>30</sup>

- (2) Let  $Y$  be the intersection of the circumcircle ( $O$ ) with the line  $I_c I_a$  (other than  $B$ ). Note that  $Y$  is the midpoint of  $I_c I_a$ . The line  $YO$  intersects  $CA$  at its midpoint  $E$  and the circumcircle again at its antipode  $Y'$ . Since  $E$  is the common midpoint of the segments  $Q_c Q_a$  and  $Q Q_b$ ,

- (i)  $YE = \frac{1}{2}(r_c + r_a)$ ;  
(ii)  $EY' = \frac{1}{2}(r_a - r)$ .

<sup>29</sup> $(\frac{1}{(s-a)^2} : \frac{1}{(s-b)^2} : \frac{1}{(s-c)^2})$ . This point appears in ETC as  $X_{279}$ . See P. Yiu, Hyacinthos, message 3359, 8/6/01.

Since  $YY' = 2R$ , we obtain the relation

$$r_a + r_b + r_c = 4R + r.$$

#### 4.6.2 Centroid of pedal triangle

We determine the centroid of the pedal triangle of  $P$  by first equalizing the coordinate sums of the pedals:

$$\begin{aligned} A_{[P]} &= (0 : S_C u + a^2 v : S_B u + a^2 w) \sim (0 : b^2 c^2 (S_C u + a^2 v) : b^2 c^2 (S_B u + a^2 w)) \\ B_{[P]} &= (S_C v + b^2 u : 0 : S_A v + b^2 w) \sim (c^2 a^2 (S_C v + b^2 u) : 0 : c^2 a^2 (S_A v + b^2 w)) \\ C_{[P]} &= (S_B w + c^2 u : S_A w + c^2 v : 0) \sim (a^2 b^2 (S_B w + c^2 u) : a^2 b^2 (S_A w + c^2 v) : 0). \end{aligned}$$

The centroid is the point

$$(2a^2 b^2 c^2 u + a^2 c^2 S_C v + a^2 b^2 S_B w : b^2 c^2 S_C u + 2a^2 b^2 c^2 v + a^2 b^2 S_A w : b^2 c^2 S_B u + c^2 a^2 S_A v + 2a^2 b^2 c^2 w).$$

This is the same point as  $P$  if and only if

$$\begin{aligned} 2a^2 b^2 c^2 u + a^2 c^2 S_C v + a^2 b^2 S_B w &= ku, \\ b^2 c^2 S_C u + 2a^2 b^2 c^2 v + a^2 b^2 S_A w &= kv, \\ b^2 c^2 S_B u + c^2 a^2 S_A v + 2a^2 b^2 c^2 w &= kw \end{aligned}$$

for some  $k$ . Adding these equations, we obtain

$$3a^2 b^2 c^2 (u + v + w) = k(u + v + w).$$

If  $P = (u : v : w)$  is a finite point, we must have  $k = 3a^2 b^2 c^2$ . The system of equations becomes

$$\begin{aligned} -a^2 b^2 c^2 u + a^2 c^2 S_C v + a^2 b^2 S_B w &= 0, \\ b^2 c^2 S_C u - a^2 b^2 c^2 v + a^2 b^2 S_A w &= 0, \\ b^2 c^2 S_B u + c^2 a^2 S_A v - a^2 b^2 c^2 w &= 0. \end{aligned}$$

Now it is easy to see that

$$\begin{aligned} b^2 c^2 u : c^2 a^2 v : a^2 b^2 w &= \begin{vmatrix} -b^2 & S_A \\ S_A & -c^2 \end{vmatrix} : - \begin{vmatrix} S_C & S_A \\ S_B & -c^2 \end{vmatrix} : \begin{vmatrix} S_C & -b^2 \\ S_B & S_A \end{vmatrix} \\ &= b^2 c^2 - S_{AA} : c^2 S_C + S_{AB} : S_{CA} + b^2 S_B \\ &= S^2 : S^2 : S^2 \\ &= 1 : 1 : 1. \end{aligned}$$

It follows that  $u : v : w = a^2 : b^2 : c^2$ , and  $P$  is the symmedian point.

**Theorem (Lemoine)**

The symmedian point is the only point which is the centroid of its own pedal triangle.

**4.6.3 Perspectors associated with inscribed squares**

Consider the square  $A_bA_cA'_cA'_b$  inscribed in triangle  $ABC$ , with  $A_b, A_c$  on  $BC$ . These have coordinates

$$\begin{aligned} A_b &= (0 : S_C + S : S_B), & A_c &= (0 : S_C : S_B + S), \\ A'_b &= (a^2 : S : 0), & A'_c &= (a^2 : 0 : S). \end{aligned}$$

Similarly, there are inscribed squares  $B_cB_aB'_aB'_c$  and  $C_aC_bC'_bC'_a$  on the other two sides.

Here is a number of perspective triangles associated with these squares.<sup>31</sup> In each case, we give the definition of  $A_n$  only.

$n$	$A_n$	Perspector of $A_nB_nC_n$
1	$BB_c \cap CC_b$	orthocenter
2	$BA'_c \cap CA'_b$	circumcenter
3	$BC'_a \cap CB'_a$	symmedian point
4	$B''_cB''_a \cap C''_aC''_b$	symmedian point
5	$B'_cB'_a \cap C'_aC'_b$	$X_{493} = (\frac{a^2}{S+b^2} : \dots : \dots)$
6	$C_bA_b \cap A_cB_c$	Kiepert perspector $K(\arctan 2)$
7	$C_aA_c \cap A_bB_a$	Kiepert perspector $K(\arctan 2)$
8	$C_aA'_c \cap B_aA'_b$	$(\frac{S_A+S}{S_A} : \dots : \dots)$
9	$C'_aA'_b \cap B'_aA'_c$	$X_{394} = (a^2S_{AA} : b^2S_{BB} : c^2S_{CC})$

For  $A_4, BCA''_cA''_b, CAB''_aB''_c$  and  $ABC''_bC''_a$  are the squares constructed externally on the sides of triangle  $ABC$ .

---

<sup>31</sup>K.R. Dean, Hyacinthos, message 3247, July 18, 2001.

# Chapter 5

## Circles I

### 5.1 Isogonal conjugates

Let  $P$  be a point with homogeneous barycentric coordinates  $(x : y : z)$ .

(1) The reflection of the cevian  $AP$  in the bisector of angle  $A$  intersects the line  $BC$  at the point  $X' = (0 : \frac{b^2}{y} : \frac{c^2}{z})$ .

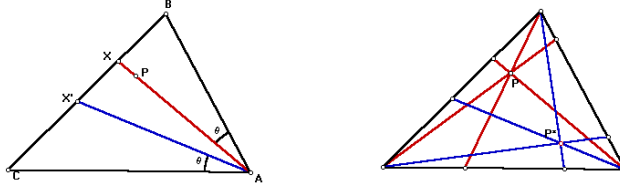

*Proof.* Let  $X$  be the  $A$ -trace of  $P$ , with  $\angle BAP = \theta$ . This is the point  $X = (0 : y : z) = (0 : S_A - S_\theta : -c^2)$  in Conway's notation. It follows that  $S_A - S_\theta : -c^2 = y : z$ . If the reflection of  $AX$  (in the bisector of angle  $A$ ) intersects  $BC$  at  $X'$ , we have  $X' = (0 : -b^2 : S_A - S_\theta) = (0 : -b^2 c^2 : c^2(S_A - S_\theta)) = (0 : b^2 z : c^2 y) = (0 : \frac{b^2}{y} : \frac{c^2}{z})$ .

(2) Similarly, the reflections of the cevians  $BP$  and  $CP$  in the respective angle bisectors intersect  $CA$  at  $Y' = (\frac{a^2}{x} : 0 : \frac{c^2}{z})$  and  $AB$  at  $Z' = (\frac{a^2}{x} : \frac{b^2}{y} : 0)$ .

(3) These points  $X', Y', Z'$  are the traces of

$$P^* = \left( \frac{a^2}{x} : \frac{b^2}{y} : \frac{c^2}{z} \right) = (a^2 y z : b^2 z x : c^2 x y).$$

The point  $P^*$  is called the *isogonal conjugate* of  $P$ . Clearly,  $P$  is the isogonal conjugate of  $P^*$ .

### 5.1.1 Examples

1. The isogonal conjugate of the centroid  $G$  is the symmedian point  $K = (a^2 : b^2 : c^2)$ .
2. The incenter is its own isogonal conjugate; so are the excenters.
3. The isogonal conjugate of the orthocenter  $H = (\frac{1}{S_A} : \frac{1}{S_B} : \frac{1}{S_C})$  is  $(a^2 S_A : b^2 S_B : c^2 S_C)$ , the circumcenter.
4. The isogonal conjugate of the Gergonne point  $G_e = (\frac{1}{s-a} : \frac{1}{s-b} : \frac{1}{s-c})$  is the point  $(a^2(s-a) : b^2(s-b) : c^2(s-c))$ , the internal center of similitude of the circumcircle and the incircle.
5. The isogonal conjugate of the Nagel point is the external center of similitude of  $(O)$  and  $(I)$ .

### Exercises

1. Let  $A', B', C'$  be the circumcenters of the triangles  $OBC, OCA, OAB$ . The triangle  $A'B'C'$  has perspector the isogonal conjugate of the nine-point center.<sup>1</sup>
2. Let  $P$  be a given point. Construct the circumcircles of the pedal triangles of  $P$  and of  $P^*$ . What can you say about these circles and their centers?
3. The *isodynamic points* are the isogonal conjugates of the Fermat points.<sup>2</sup>
  - (a) Construct the positive isodynamic point  $F_+^*$ . This is a point on the line joining  $O$  and  $K$ . How does this point divide the segment  $OK$ ?
  - (b) Construct the pedal triangle of  $F_+^*$ . What can you say about this triangle?
4. Show that the isogonal conjugate of the Kiepert perspector  $K(\theta) = (\frac{1}{S_A+S_\theta} : \frac{1}{S_B+S_\theta} : \frac{1}{S_C+S_\theta})$  is always on the line  $OK$ . How does this point divide the segment  $OK$ ?
5. The perpendiculars from the vertices of  $ABC$  to the corresponding sides of the pedal triangle of a point  $P$  concur at the isogonal conjugate of  $P$ .

<sup>1</sup>This is also known as the Kosnita point, and appears in ETC as the point  $X_{54}$ .

<sup>2</sup>These appear in ETC as the points  $X_{15}$  and  $X_{16}$ .



## 5.2 The circumcircle as the isogonal conjugate of the line at infinity

Let  $P$  be a point on the circumcircle.

(1) If  $AX$  and  $AP$  are symmetric with respect to the bisector of angle  $A$ , and  $BY$ ,  $BP$  symmetric with respect to the bisector of angle  $B$ , then  $AX$  and  $BY$  are parallel.

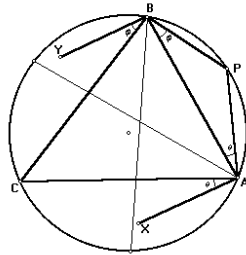

*Proof.* Suppose  $\angle PAB = \theta$  and  $\angle PBA = \varphi$ . Note that  $\theta + \varphi = C$ . Since  $\angle XAB = A + \theta$  and  $\angle YBA = B + \varphi$ , we have  $\angle XAB + \angle YBA = 180^\circ$  and  $AX$ ,  $BY$  are parallel.

(2) Similarly, if  $CZ$  and  $CP$  are symmetric with respect to the bisector of angle  $C$ , then  $CZ$  is parallel to  $AX$  and  $BY$ .

It follows that the isogonal conjugate of a point on the circumcircle is an infinite point, and conversely. We may therefore regard the circumcircle as the isogonal conjugate of the line at infinity. As such, the circumcircle has equation

$$a^2yz + b^2zx + c^2xy = 0.$$

### Exercises

1. **Animate** a point  $P$  on the circumcircle.
  - (1) Construct the **locus of isogonal conjugates** of points on the line  $OP$ .
  - (2) Construct the isogonal conjugate  $Q$  of the infinite point of the line  $OP$ .

The point lies on the locus in (1).
2. **Animate** a point  $P$  on the circumcircle. Find the **locus of the isotomic conjugate  $P^\bullet$** .<sup>3</sup>

---

<sup>3</sup>The line  $a^2x + b^2y + c^2z = 0$ .

3. Let  $P$  and  $Q$  be antipodal points on the circumcircle. The lines  $PQ^\bullet$  and  $QP^\bullet$  joining each of these points to the **isotomic conjugate** of the other intersect orthogonally on the circumcircle.
4. Let  $P$  and  $Q$  be antipodal points on the circumcircle. What is the locus of the intersection of  $PP^\bullet$  and  $QQ^\bullet$ ?
5. Let  $P = (u : v : w)$ . The lines  $AP$ ,  $BP$ ,  $CP$  intersect the circumcircle again at the points

$$\begin{aligned} A^{(P)} &= \left( \frac{-a^2vw}{c^2v + b^2w} : v : w \right), \\ B^{(P)} &= \left( u : \frac{-b^2wu}{a^2w + c^2u} : w \right), \\ C^{(P)} &= \left( u : v : \frac{-c^2uv}{b^2u + a^2v} \right). \end{aligned}$$

These form the vertices of the *Circumcevian triangle* of  $P$ .

- (a) The circumcevian triangle of  $P$  is always similar to the pedal triangle.

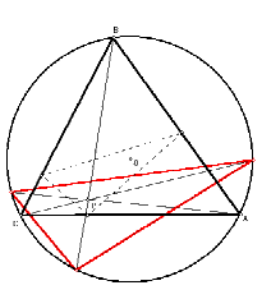

- (b) The circumcevian triangle of the incenter is perspective with  $ABC$ . What is the perspector? <sup>4</sup>

- (c) The circumcevian triangle of  $P$  is always perspective with the tangential triangle. What is the perspector? <sup>5</sup>

<sup>4</sup>The external center of similitude of the circumcircle and the incircle.

<sup>5</sup> $(a^2(-\frac{a^4}{u^2} + \frac{b^4}{v^2} + \frac{c^4}{w^2}) : \dots : \dots)$ .

### 5.3 Simson lines

Consider the pedals of a point  $P = (u : v : w)$ :

$$\begin{aligned} A_{[P]} &= (0 : S_C u + a^2 v : S_B u + a^2 w), \\ B_{[P]} &= (S_C v + b^2 u : 0 : S_A v + b^2 w), \\ C_{[P]} &= (S_B w + c^2 u : S_A w + c^2 v : 0). \end{aligned}$$

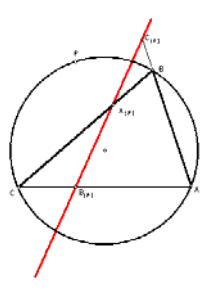

These pedals of  $P$  are collinear if and only if  $P$  lies on the circumcircle, since

$$\begin{aligned} & \begin{vmatrix} 0 & S_C u + a^2 v & S_B u + a^2 w \\ S_C v + b^2 u & 0 & S_A v + b^2 w \\ S_B w + c^2 u & S_A w + c^2 v & 0 \end{vmatrix} \\ = & (u + v + w) \begin{vmatrix} a^2 & S_C u + a^2 v & S_B u + a^2 w \\ b^2 & 0 & S_A v + b^2 w \\ c^2 & S_A w + c^2 v & 0 \end{vmatrix} \\ & \vdots \quad \dots \\ = & (u + v + w)(S_{AB} + S_{BC} + S_{CA})(a^2 v w + b^2 w u + c^2 u v). \end{aligned}$$

If  $P$  lies on the circumcircle, the line containing the pedals is called the *Simson line*  $s(P)$  of  $P$ . If we write the coordinates of  $P$  in the form  $(\frac{a^2}{f} : \frac{b^2}{g} : \frac{c^2}{h}) = (a^2 g h : b^2 h f : c^2 f g)$  for an infinite point  $(f : g : h)$ , then

$$\begin{aligned} A_{[P]} &= (0 : a^2 S_C g h + a^2 b^2 h f : a^2 S_B g h + a^2 c^2 f g) \\ &\sim (0 : h(-S_C(h + f) + (S_C + S_A)f) : g(-S_B(f + g) + (S_A + S_B)f)) \\ &\sim (0 : -h(S_C h - S_A f) : g(S_A f - S_B g)). \end{aligned}$$

This becomes  $A_{[P]} = (0 : -h g' : g h')$  if we write  $(f' : g' : h') = (S_B g - S_C h : S_C h - S_A f : S_A f - S_B g)$  for the infinite point of lines in the direction

perpendicular to  $(f : g : h)$ . Similarly,  $B_{[P]} = (hf' : 0 : -fh')$  and  $C_{[P]} = (-gf' : fg' : 0)$ . The equation of the Simson line is

$$\frac{f}{f'}x + \frac{g}{g'}y + \frac{h}{h'}z = 0.$$

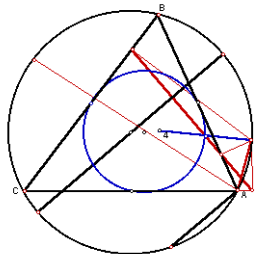

It is easy to determine the infinite point of the Simson line:

$$\begin{aligned} B_{[P]} - C_{[P]} &= c^2(S_Cv + b^2u : 0 : S_Av + b^2w) - b^2(S_Bw + c^2u : S_Aw + c^2v : 0) \\ &= (** : -b^2(S_Aw + c^2v) : c^2(S_Av + b^2w)) \\ &\vdots \quad \dots \\ &= (** : S_Ch - S_Af : S_Af - S_Bg) \\ &= (f' : g' : h'). \end{aligned}$$

The Simson line  $s(P)$  is therefore perpendicular to the line defining  $P$ . It passes through, as we have noted, the midpoint between  $H$  and  $P$ , which lies on the nine-point circle.

### 5.3.1 Simson lines of antipodal points

Let  $P$  and  $Q$  be antipodal points on the circumcircle. They are isogonal conjugates of the infinite points of perpendicular lines.

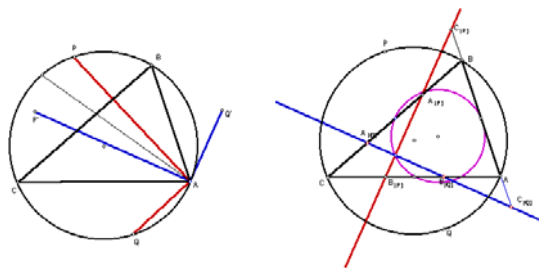

Therefore, the Simson lines  $s(P)$  and  $s(Q)$  are perpendicular to each other. Since the midpoints of  $HP$  and  $HQ$  are antipodal on the nine-point circle, the two Simson lines intersect on the nine-point circle.

## Exercises

1. **Animate** a point  $P$  on the circumcircle of triangle  $ABC$  and **trace** its Simson line.
2. Let  $H$  be the orthocenter of triangle  $ABC$ , and  $P$  a point on the circumcircle. Show that the midpoint of  $HP$  lies on the Simson line  $s(P)$  and on the nine-point circle of triangle  $ABC$ .
3. Let  $\mathcal{L}$  be the line  $\frac{x}{u} + \frac{y}{v} + \frac{z}{w} = 0$ , intersecting the side lines  $BC$ ,  $CA$ ,  $AB$  of triangle  $ABC$  at  $U$ ,  $V$ ,  $W$  respectively.
  - (a) Find the equation of the perpendiculars to  $BC$ ,  $CA$ ,  $AB$  at  $U$ ,  $V$ ,  $W$  respectively.<sup>6</sup>
  - (b) Find the coordinates of the vertices of the triangle bounded by these three perpendiculars.<sup>7</sup>
  - (c) Show that this triangle is perspective with  $ABC$  at a point  $P$  on the circumcircle.<sup>8</sup>
  - (d) Show that the Simson line of the point  $P$  is parallel to  $\mathcal{L}$ .

## 5.4 Equation of the nine-point circle

To find the equation of the nine-point circle, we make use of the fact that it is obtained from the circumcircle by applying the homothety  $h(G, \frac{1}{2})$ . If  $P = (x : y : z)$  is a point on the nine-point circle, then the point

$$Q = 3G - 2P = (x+y+z)(1 : 1 : 1) - 2(x : y : z) = (y+z-x : z+x-y : x+y-z)$$

is on the circumcircle. From the equation of the circumcircle, we obtain

$$a^2(z+x-y)(x+y-z) + b^2(x+y-z)(y+z-x) + c^2(y+z-x)(z+x-y) = 0.$$

Simplifying this equation, we have

$$0 = \sum_{\text{cyclic}} a^2(x^2 - y^2 + 2yz - z^2) = \sum_{\text{cyclic}} (a^2 - c^2 - b^2)x^2 + 2a^2yz,$$

or

$$\sum_{\text{cyclic}} S_A x^2 - a^2 yz = 0.$$

<sup>6</sup> $(S_B v + S_C w)x + a^2 w y + a^2 v z = 0$ , etc.

<sup>7</sup> $(-S^2 u^2 + S_{AB} uv + S_{BC} vw + S_{CA} wu : b^2(c^2 uv - S_A uv - S + Bvw) : c^2(b^2 uv - S_A uv - S_C vw))$ .

<sup>8</sup> $P = \left( \frac{a^2}{-a^2 vw + S_B uv + S_C wv} : \dots : \dots \right)$ .

**Exercises**

1. Verify that the midpoint between the Fermat points, namely, the point with coordinates

$$((b^2 - c^2)^2 : (c^2 - a^2)^2 : (a^2 - b^2)^2),$$

lies on the nine-point circle.

**5.5 Equation of a general circle**

Every circle  $\mathcal{C}$  is homothetic to the circumcircle by a homothety, say  $h(T, k)$ , where  $T = uA + vB + wC$  (in absolute barycentric coordinate) is a center of similitude of  $\mathcal{C}$  and the circumcircle. This means that if  $P(x : y : z)$  is a point on the circle  $\mathcal{C}$ , then

$$h(T, k)(P) = kP + (1-k)T \sim (x + tu(x+y+z) : y + tv(x+y+z) : z + tw(x+y+z)),$$

where  $t = \frac{1-k}{k}$ , lies on the circumcircle. In other words,

$$\begin{aligned} 0 &= \sum_{\text{cyclic}} a^2 (ty + v(x+y+z))(tz + w(x+y+z)) \\ &= \sum_{\text{cyclic}} a^2 (yz + t(wy + vz))(x+y+z) + t^2 vw(x+y+z)^2 \\ &= (a^2 yz + b^2 zx + c^2 xy) + t \left( \sum_{\text{cyclic}} a^2 (wy + vz) \right) (x+y+z) \\ &\quad + t^2 (a^2 vw + b^2 wu + c^2 uv) (x+y+z)^2 \end{aligned}$$

Note that the last two terms factor as the product of  $x+y+z$  and another *linear form*. It follows that every circle can be represented by an equation of the form

$$a^2 yz + b^2 zx + c^2 xy + (x+y+z)(px + qy + rz) = 0.$$

The line  $px + qy + rz = 0$  is the *radical axis* of  $\mathcal{C}$  and the circumcircle.

**Exercises**

1. The radical axis of the circumcircle and the nine-point circle is the line

$$S_A x + S_B y + S_C z = 0.$$

2. The circle through the excenters has center at the reflection of  $I$  in  $O$ , and radius  $2R$ . Find its equation.<sup>9</sup>

---

<sup>9</sup> $a^2 yz + b^2 zx + c^2 xy + (x+y+z)(bcx + cay + abz) = 0.$

## 5.6 Appendix: Miquel Theory

### 5.6.1 Miquel Theorem

Let  $X, Y, Z$  be points on the lines  $BC, CA,$  and  $AB$  respectively. The three circles  $AYZ, BZX,$  and  $CXY$  pass through a common point.

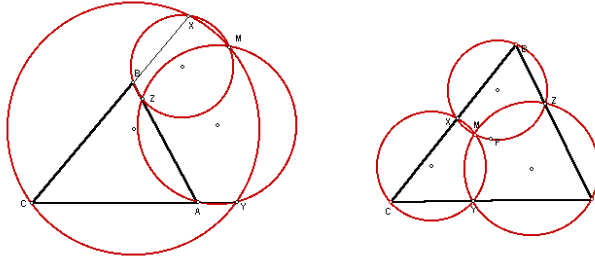

### 5.6.2 Miquel associate

Suppose  $X, Y, Z$  are the traces of  $P = (u : v : w)$ . We determine the equation of the circle  $AYZ$ .<sup>10</sup> Writing it in the form

$$a^2yz + b^2zx + c^2xy + (x + y + z)(px + qy + rz) = 0$$

we note that  $p = 0$  since it passes through  $A = (1 : 0 : 0)$ . Also, with  $(x : y : z) = (u : 0 : w)$ , we obtain  $r = -\frac{b^2u}{w+u}$ . Similarly, with  $(x : y : z) = (u : v : 0)$ , we obtain  $q = -\frac{c^2u}{u+v}$ . The equation of the circle

$$\mathcal{C}_{AYZ} : a^2yz + b^2zx + c^2xy - (x + y + z) \left( \frac{c^2u}{u+v}y + \frac{b^2u}{w+u}z \right) = 0.$$

Likewise, the equations of the other two circles are

$$\mathcal{C}_{BZX} : a^2yz + b^2zx + c^2xy - (x + y + z) \left( \frac{c^2v}{u+v}x + \frac{a^2v}{v+w}z \right) = 0,$$

and the one through  $C, X,$  and  $Y$  has equation

$$\mathcal{C}_{CXY} : a^2yz + b^2zx + c^2xy - (x + y + z) \left( \frac{b^2w}{w+u}x + \frac{a^2w}{v+w}y \right) = 0.$$

By Miquel's Theorem, the three circles intersect at a point  $P'$ , which we call the *Miquel associate* of  $P$ . The coordinates of  $P'$  satisfy the equations

$$\frac{c^2u}{u+v}y + \frac{b^2u}{w+u}z = \frac{c^2v}{u+v}x + \frac{a^2v}{v+w}z = \frac{b^2w}{w+u}x + \frac{a^2w}{v+w}y.$$

<sup>10</sup>For the case when  $X, Y, Z$  are the intercepts of a line, see J.P. Ehrmann, *Steiner's theorems on the complete quadrilateral*, Forum Geometricorum, forthcoming.

Solving these equations, we have

$$\begin{aligned}
 P' &= \left( \frac{a^2}{v+w} \left( -\frac{a^2vw}{v+w} + \frac{b^2wu}{w+u} + \frac{c^2uv}{u+v} \right), \right. \\
 &: \frac{b^2}{w+u} \left( \frac{a^2vw}{v+w} - \frac{b^2wu}{w+u} + \frac{c^2uv}{u+v} \right), \\
 &: \left. \frac{c^2}{u+v} \left( \frac{a^2vw}{v+w} + \frac{b^2wu}{w+u} - \frac{c^2uv}{u+v} \right) \right).
 \end{aligned}$$

### Examples

$P$	Miquel associate $P'$
centroid	circumcenter
orthocenter	orthocenter
Gergonne point	incenter
incenter	$\left( \frac{a^2(a^3+a^2(b+c)-a(b^2+bc+c^2)-(b+c)(b^2+c^2))}{b+c} : \dots : \dots \right)$
Nagel Point	$(a(a^3+a^2(b+c)-a(b+c)^2-(b+c)(b-c)^2) : \dots : \dots)$

### 5.6.3 Cevian circumcircle

The cevian circumcircle of  $P$  is the circle through its traces. This has equation

$$(a^2yz + b^2zx + c^2xy) - (x+y+z)(px + qy + rz) = 0,$$

where

$$vq + wr = \frac{a^2vw}{v+w}, \quad up + wr = \frac{b^2wu}{w+u}, \quad up + vq = \frac{c^2uv}{u+v}.$$

Solving these equations, we have

$$\begin{aligned}
 p &= \frac{1}{2u} \left( -\frac{a^2vw}{v+w} + \frac{b^2wu}{w+u} + \frac{c^2uv}{u+v} \right), \\
 q &= \frac{1}{2v} \left( \frac{a^2vw}{v+w} - \frac{b^2wu}{w+u} + \frac{c^2uv}{u+v} \right), \\
 r &= \frac{1}{2w} \left( \frac{a^2vw}{v+w} + \frac{b^2wu}{w+u} - \frac{c^2uv}{u+v} \right).
 \end{aligned}$$



### 5.6.4 Cyclocevian conjugate

The cevian circumcircle intersects the line  $BC$  at the points given by

$$a^2yz - (y + z)(qy + rz) = 0.$$

This can be rearranged as

$$qy^2 + (q + r - a^2)yz + rz^2 = 0.$$

The product of the two roots of  $y : z$  is  $\frac{r}{q}$ . Since one of the roots  $y : z = v : w$ , the other root is  $\frac{rw}{qv}$ . The second intersection is therefore the point

$$X' = 0 : rw : qv = 0 : \frac{1}{qv} : \frac{1}{rw}.$$

Similarly, the “second” intersections of the circle  $XYZ$  with the other two sides can be found. The cevians  $AX'$ ,  $BY'$ , and  $CZ'$  intersect at the point  $(\frac{1}{pu} : \frac{1}{qv} : \frac{1}{rw})$ . We denote this by  $c(P)$  and call it the *cyclocevian conjugate* of  $P$ . Explicitly,

$$c(P) = \left( \frac{1}{-\frac{a^2vw}{v+w} + \frac{b^2wu}{w+u} + \frac{c^2uv}{u+v}} : \frac{1}{\frac{a^2vw}{v+w} - \frac{b^2wu}{w+u} + \frac{c^2uv}{u+v}} : \frac{1}{\frac{a^2vw}{v+w} + \frac{b^2wu}{w+u} - \frac{c^2uv}{u+v}} \right).$$

#### Examples

1. The centroid and the orthocenter are cyclocevian conjugates, their common cevian circumcircle being the nine-point circle.
2. The cyclocevian conjugate of the incenter is the point

$$\left( \frac{1}{a^3 + a^2(b+c) - a(b^2 + bc + c^2) - (b+c)(b^2 + c^2)} : \cdots : \cdots \right).$$

#### Theorem

Given a point  $P$ , let  $P'$  be its Miquel associate and  $Q$  its cyclocevian conjugate, with Miquel associate  $Q'$ .

- (a)  $P'$  and  $Q'$  are isogonal conjugates.
- (b) The lines  $PQ$  and  $P'Q'$  are parallel.
- (c) The “second intersections” of the pairs of circles  $AYZ, AY'Z'$ ;  $BZX, BZ'X'$ ; and  $CXY, CX'Y'$  form a triangle  $A'B'C'$  perspective with  $ABC$ .
- (e) The “Miquel perspector” in (c) is the intersection of the trilinear polars of  $P$  and  $Q$  with respect to triangle  $ABC$ .

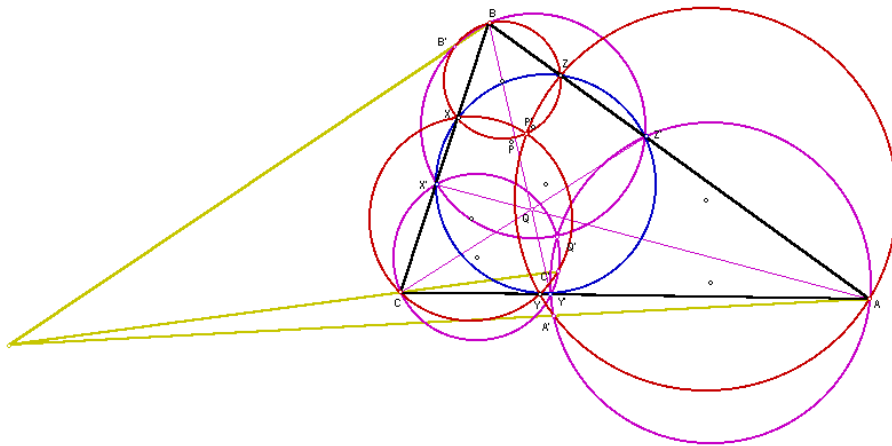

### Exercises

1. For a real number  $t$ , we consider the triad of points

$$X_t = (0 : 1 - t : t), \quad Y_t = (t : 0 : 1 - t), \quad Z_t = (1 - t : t : 0)$$

on the sides of the reference triangle.

- (a) The circles  $AY_tZ_t$ ,  $BZ_tX_t$  and  $CX_tY_t$  intersect at the point

$$\begin{aligned} M_t &= (a^2(-a^2t(1-t) + b^2t^2 + c^2(1-t)^2) \\ &\quad : b^2(a^2(1-t)^2 - b^2t(1-t) + c^2t^2) \\ &\quad : c^2(a^2t^2 + b^2(1-t)^2 - c^2t(1-t)). \end{aligned}$$

- (b) Writing  $M_t = (x : y : z)$ , eliminate  $t$  to obtain the following equation in  $x, y, z$ :

$$b^2c^2x^2 + c^2a^2y^2 + a^2b^2z^2 - c^4xy - b^4zx - a^4yz = 0.$$

- (c) Show that the locus of  $M_t$  is a circle.  
 (d) Verify that this circle contains the circumcenter, the symmedian point, and the two *Brocard points*

$$\Omega_{\leftarrow} = \left( \frac{1}{b^2} : \frac{1}{c^2} : \frac{1}{a^2} \right),$$

and

$$\Omega_{\rightarrow} = \left( \frac{1}{c^2} : \frac{1}{a^2} : \frac{1}{b^2} \right).$$

# Chapter 6

## Circles II

### 6.1 Equation of the incircle

Write the equation of the incircle in the form

$$a^2yz + b^2zx + c^2xy - (x + y + z)(px + qy + rz) = 0$$

for some undetermined coefficients  $p, q, r$ . Since the incircle touches the side  $BC$  at the point  $(0 : s - c : s - b)$ ,  $y : z = s - c : s - b$  is the only root of the quadratic equation  $a^2yz + (y + z)(qy + rz) = 0$ . This means that

$$qy^2 + (q + r - a^2)yz + rz^2 = k((s - b)y - (s - c)z)^2$$

for some scalar  $k$ .

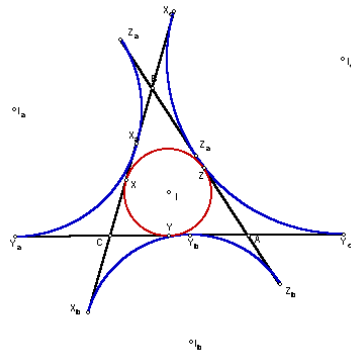

Comparison of coefficients gives  $k = 1$  and  $q = (s - b)^2$ ,  $r = (s - c)^2$ . Similarly, by considering the tangency with the line  $CA$ , we obtain  $p =$

$(s - a)^2$  and (consistently)  $r = (s - c)^2$ . It follows that the equation of the incircle is

$$a^2yz + b^2zx + c^2xy - (x + y + z)((s - a)^2x + (s - b)^2y + (s - c)^2z) = 0.$$

The radical axis with the circumcircle is the line

$$(s - a)^2x + (s - b)^2y + (s - c)^2z = 0.$$

### 6.1.1 The excircles

The same method gives the equations of the excircles:

$$\begin{aligned} a^2yz + b^2zx + c^2xy - (x + y + z)(s^2x + (s - c)^2y + (s - b)^2z) &= 0, \\ a^2yz + b^2zx + c^2xy - (x + y + z)((s - c)^2x + s^2y + (s - a)^2z) &= 0, \\ a^2yz + b^2zx + c^2xy - (x + y + z)((s - b)^2x + (s - a)^2y + s^2z) &= 0. \end{aligned}$$

### Exercises

1. Show that the Nagel point of triangle  $ABC$  lies *on* its incircle if and only if one of its sides is equal to  $\frac{s}{2}$ . Make use of this to design an animation picture showing a triangle with its Nagel point on the incircle.
2. (a) Show that the centroid of triangle  $ABC$  lies on the incircle if and only if  $5(a^2 + b^2 + c^2) = 6(ab + bc + ca)$ .  
 (b) Let  $ABC$  be an *equilateral* triangle with center  $O$ , and  $\mathcal{C}$  the circle, center  $O$ , radius half that of the incircle of  $ABC$ . Show that the distances from an arbitrary point  $P$  on  $\mathcal{C}$  to the sidelines of  $ABC$  are the lengths of the sides of a triangle whose centroid is on the incircle.

## 6.2 Intersection of the incircle and the nine-point circle

We consider how the incircle and the nine-point circle intersect. The intersections of the two circles can be found by solving their equations simultaneously:

$$a^2yz + b^2zx + c^2xy - (x + y + z)((s - a)^2x + (s - b)^2y + (s - c)^2z) = 0,$$

$$a^2yz + b^2zx + c^2xy - \frac{1}{2}(x + y + z)(S_Ax + S_By + S_Cz) = 0.$$

### 6.2.1 Radical axis of $(I)$ and $(N)$

Note that

$$(s-a)^2 - \frac{1}{2}S_A = \frac{1}{4}((b+c-a)^2 - (b^2+c^2-a^2)) = \frac{1}{2}(a^2 - a(b+c) + bc) = \frac{1}{2}(a-b)(a-c).$$

Subtracting the two equations we obtain the equation of the radical axis of the two circles:

$$\mathcal{L} : (a-b)(a-c)x + (b-a)(b-c)y + (c-a)(c-b)z = 0.$$

We rewrite this as

$$\frac{x}{b-c} + \frac{y}{c-a} + \frac{z}{a-b} = 0.$$

There are two points with simple coordinates on this line:

$$P = ((b-c)^2 : (c-a)^2 : (a-b)^2),$$

and

$$Q = (a(b-c)^2 : b(c-a)^2 : c(a-b)^2).$$

Making use of these points we obtain a very simple parametrization of points on the radical axis  $\mathcal{L}$ , except  $P$ :

$$(x : y : z) = ((a+t)(b-c)^2 : (b+t)(c-a)^2 : (c+t)(a-b)^2)$$

for some  $t$ .

### 6.2.2 The line joining the incenter and the nine-point center

We find the intersection of the radical axis  $\mathcal{L}$  and the line joining the centers  $I$  and  $N$ . It is convenient to write the coordinates of the nine-point center in terms of  $a, b, c$ . Thus,

$$N = (a^2(b^2+c^2) - (b^2-c^2)^2 : b^2(c^2+a^2) - (c^2-a^2)^2 : c^2(a^2+b^2) - (a^2-b^2)^2)$$

with coordinate sum  $8S^2$ .<sup>1</sup>

---

<sup>1</sup>Start with  $N = (S^2 + S_{BC} : \dots : \dots)$  (with coordinate sum  $4S^2$ ) and rewrite  $S^2 + S_{BC} = \dots = \frac{1}{2}(a^2(b^2+c^2) - (b^2-c^2)^2)$ .

We seek a real number  $k$  for which the point

$$\begin{aligned} & (a^2(b^2 + c^2) - (b^2 - c^2)^2 + ka \\ : & b^2(c^2 + a^2) - (c^2 - a^2)^2 + kb \\ : & c^2(a^2 + b^2) - (a^2 - b^2)^2 + kc \end{aligned}$$

on the line  $IN$  also lies on the radical axis  $\mathcal{L}$ . With  $k = -2abc$ , we have

$$\begin{aligned} & a^2(b^2 + c^2) - (b^2 - c^2)^2 - 2a^2bc \\ = & a^2(b - c)^2 - (b^2 - c^2)^2 \\ = & (b - c)^2(a^2 - (b + c)^2) \\ = & 4s(a - s)(b - c)^2, \end{aligned}$$

and two analogous expressions by cyclic permutations of  $a, b, c$ . These give the coordinates of a point on  $\mathcal{L}$  with  $t = -s$ , and we conclude that the two lines intersect at the *Feuerbach point*

$$F = ((s - a)(b - c)^2 : (s - b)(c - a)^2 : (s - c)(a - b)^2).$$

We proceed to determine the ratio of division  $IF : FN$ . From the choice of  $k$ , we have

$$F \sim 8S^2 \cdot N - 2abc \cdot 2s \cdot I = 8S^2 \cdot N - 4sabc \cdot I.$$

This means that

$$NF : FI = -4sabc : 8S^2 = -8sRS : 8S^2 = -sR : S = R : -2r = \frac{R}{2} : -r.$$

The point  $F$  is the external center of similitude of the nine-point circle and the incircle.

However, if a center of similitude of two circles lies on their radical axis, the circles must be tangent to each other (at that center).<sup>2</sup>

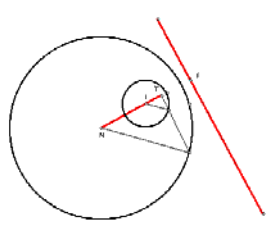

<sup>2</sup>Proof: Consider two circles of radii  $p$  and  $q$ , centers at a distance  $d$  apart. Suppose the intersection of the radical axis and the center line is at a distance  $x$  from the center of the circle of radius  $p$ , then  $x^2 - p^2 = (d - x)^2 - q^2$ . From this,  $x = \frac{d^2 + p^2 - q^2}{2d}$ , and  $d - x = \frac{d^2 - p^2 + q^2}{2d}$ . The division ratio is  $x : d - x = d^2 + p^2 - q^2 : d^2 - p^2 + q^2$ . If this is equal to  $p : -q$ , then  $p(d^2 - p^2 + q^2) + q(d^2 + p^2 - q^2) = 0$ ,  $(p + q)(d^2 - (p - q)^2) = 0$ . From this  $d = |p - q|$ , and the circles are tangent internally.

**Feuerbach's Theorem**

The nine-point circle and the incircle are tangent internally to each other at the point  $F$ , the common tangent being the line

$$\frac{x}{b-c} + \frac{y}{c-a} + \frac{z}{a-b} = 0.$$

The nine-point circle is tangent to each of the excircles externally. The points of tangency form a triangle perspective with  $ABC$  at the point

$$F' = \left( \frac{(b+c)^2}{s-a} : \frac{(c+a)^2}{s-b} : \frac{(a+b)^2}{s-c} \right).$$

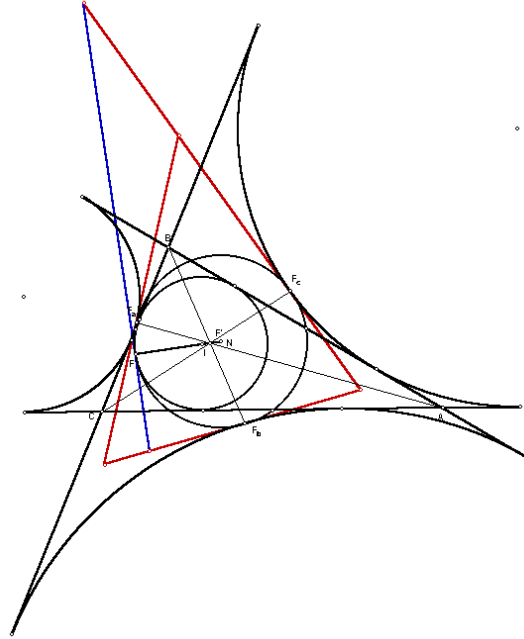
**Exercises**

1. Show that  $F$  and  $F'$  divide  $I$  and  $N$  harmonically.
2. Find the equations of the common tangent of the nine-point circle and the excircles. <sup>3</sup>

<sup>3</sup>Tangent to the  $A$ -excircle:  $\frac{x}{b-c} + \frac{y}{c+a} - \frac{z}{a+b} = 0$ .

3. Apart from the common external tangent, the nine-point circle and the  $A$ -circle have another pair of common internal tangent, intersecting at their excenter of similitude  $A'$ . Similarly define  $B'$  and  $C'$ . The triangle  $A'B'C'$  is perspective with  $ABC$ . What is the perspector? <sup>4</sup>
4. Let  $\ell$  be a diameter of the circumcircle of triangle  $ABC$ . Animate a point  $P$  on  $\ell$  and construct its *pedal circle*, the circle through the pedals of  $P$  on the side lines. The pedal circle always passes through a fixed point on the nine-point circle. What is this fixed point if the diameter passes through the incenter?

### 6.3 The excircles

Consider the radical axes of the excircles with the circumcircle. These are the lines

$$\begin{aligned} s^2x + (s-c)^2y + (s-b)^2z &= 0, \\ (s-c)^2x + s^2y + (s-a)^2z &= 0, \\ (s-b)^2x + (s-a)^2y + s^2z &= 0. \end{aligned}$$

These three lines bound a triangle with vertices

$$\begin{aligned} A' &= (-(b+c)(a^2 + (b+c)^2) : b(a^2 + b^2 - c^2) : c(c^2 + a^2 - b^2)), \\ B' &= a(a^2 + b^2 - c^2) : -(c+a)(b^2 + (c+a)^2) : c(b^2 + c^2 - a^2) \\ C' &= a(c^2 + a^2 - b^2) : b(c^2 + (a+b)^2) : c(a^2 + b^2 - c^2). \end{aligned}$$

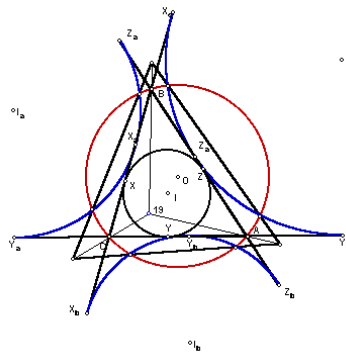

The triangle  $A'B'C'$  is perspective with  $ABC$  at the Clawson point <sup>5</sup>

$$\left( \frac{a}{S_A} : \frac{b}{S_B} : \frac{c}{S_C} \right).$$

<sup>4</sup>The Feuerbach point.

<sup>5</sup>This point appears in ETC as the point  $X_{19}$ .



**Exercises**

1. Let  $A_H$  be the pedal of  $A$  on the opposite side  $BC$  of triangle  $ABC$ . Construct circle  $B(A_H)$  to intersect  $AB$  at  $C_b$  and  $C'_b$  (so that  $C'_b$  is on the extension of  $AB$ ), and circle  $C(A_H)$  to intersect  $AC$  at  $B_c$  and  $B'_c$  (so that  $B'_c$  is on the extension of  $AC$ ).

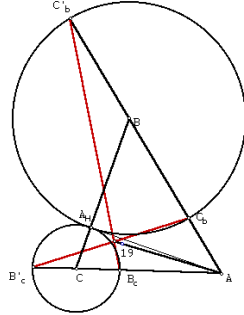

- (a) Let  $A_1$  be the intersection of the lines  $B_c B'_c$  and  $C_b C'_b$ . Similarly define  $B_1$  and  $C_1$ . Show that  $A_1 B_1 C_1$  is perspective with  $ABC$  at the Clawson point.<sup>6</sup>
  - (b) Let  $A_2 = BB_c \cap CC_b$ ,  $B_2 = CC_a \cap AA_c$ , and  $C_2 = AA_b \cap BB_a$ . Show that  $A_2 B_2 C_2$  is perspective with  $ABC$ . Calculate the coordinates of the perspector.<sup>7</sup>
  - (c) Let  $A_3 = BB'_c \cap CC'_b$ ,  $B_3 = CC'_a \cap AA'_c$ , and  $C_3 = AA'_b \cap BB'_a$ . Show that  $A_3 B_3 C_3$  is perspective with  $ABC$ . Calculate the coordinates of the perspector.<sup>8</sup>
2. Consider the  $B$ - and  $C$ -excircles of triangle  $ABC$ . Three of their common tangents are the side lines of triangle  $ABC$ . The fourth common tangent is the reflection of the line  $BC$  in the line joining the excenters  $I_b$  and  $I_c$ .
  - (a) Find the equation of this fourth common tangent, and write down the equations of the fourth common tangents of the other two pairs of excircles.
  - (b) Show that the triangle bounded by these 3 fourth common tangents is homothetic to the orthic triangle, and determine the homothetic center.<sup>9</sup>

<sup>6</sup> A.P.Hatzipolakis, Hyacinthos, message 1663, October 25, 2000.

<sup>7</sup>  $X_{278} = (\frac{1}{(s-a)S_A} : \dots : \dots)$

<sup>8</sup>  $X_{281} = (\frac{s-a}{S_A} : \dots : \dots)$

<sup>9</sup> The Clawson point. See R. Lyness and G.R. Veldkamp, Problem 682 and solution,

## 6.4 The Brocard points

Consider the circle through the vertices  $A$  and  $B$  and tangent to the side  $AC$  at the vertex  $A$ . Since the circle passes through  $A$  and  $B$ , its equation is of the form

$$a^2yz + b^2zx + c^2xy - rz(x + y + z) = 0$$

for some constant  $r$ . Since it is tangent to  $AC$  at  $A$ , when we set  $y = 0$ , the equation should reduce to  $z^2 = 0$ . This means that  $r = b^2$  and the circle is

$$\mathcal{C}_{AAB} : a^2yz + b^2zx + c^2xy - b^2z(x + y + z) = 0.$$

Similarly, we consider the analogous circles

$$\mathcal{C}_{BBC} : a^2yz + b^2zx + c^2xy - c^2x(x + y + z) = 0.$$

and

$$\mathcal{C}_{CCA} : a^2yz + b^2zx + c^2xy - a^2y(x + y + z) = 0.$$

These three circles intersect at the *forward Brocard point*

$$\Omega_{\rightarrow} = \left( \frac{1}{c^2} : \frac{1}{a^2} : \frac{1}{b^2} \right).$$

This point has the property that

$$\angle AB\Omega_{\rightarrow} = \angle BC\Omega_{\rightarrow} = \angle CA\Omega_{\rightarrow}.$$

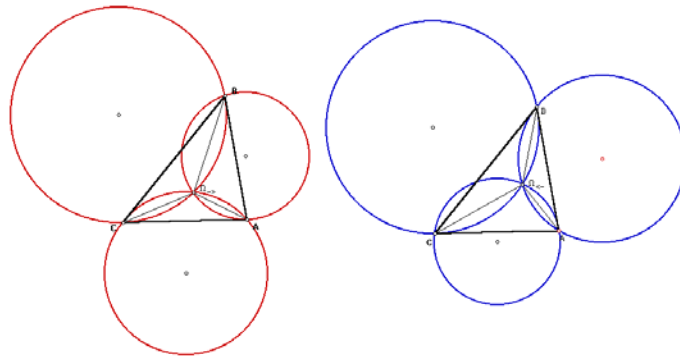

In reverse orientations there are three circles  $\mathcal{C}_{ABB}$ ,  $\mathcal{C}_{BCC}$ , and  $\mathcal{C}_{CAA}$  intersecting at the *backward Brocard point*

$$\Omega_{\leftarrow} = \left( \frac{1}{b^2} : \frac{1}{c^2} : \frac{1}{a^2} \right).$$

satisfying

$$\angle B A \Omega_{\leftarrow} = \angle C B \Omega_{\leftarrow} = \angle A C \Omega_{\leftarrow}.$$

Note from their coordinates that the two Brocard points are isogonal conjugates. This means that the 6 angles listed above are all equal. We denote the common value by  $\omega$  and call this the *Brocard angle* of triangle  $ABC$ . By writing the coordinates of  $\Omega_{\rightarrow}$  in Conway's notation, it is easy to see that

$$\cot \omega = \frac{1}{2}(S_A + S_B + S_C).$$

The lines  $B\Omega_{\rightarrow}$  and  $C\Omega_{\leftarrow}$  intersect at  $A_{-\omega}$ . Similarly, we have  $B_{-\omega} = C\Omega_{\rightarrow} \cap A\Omega_{\leftarrow}$ , and  $C_{-\omega} = A\Omega_{\rightarrow} \cap B\Omega_{\leftarrow}$ . Clearly the triangle  $A_{-\omega}B_{-\omega}C_{-\omega}$  is perspective to  $ABC$  at the point

$$K(-\omega) = \left( \frac{1}{S_A - S_\omega} : \dots : \dots \right) \sim \dots \sim \left( \frac{1}{a^2} : \dots : \dots \right),$$

which is the isotomic conjugate of the symmedian point.<sup>10</sup>

---

<sup>10</sup>This is also known as the *third Brocard point*. It appears as the point  $X_{76}$  in ETC.

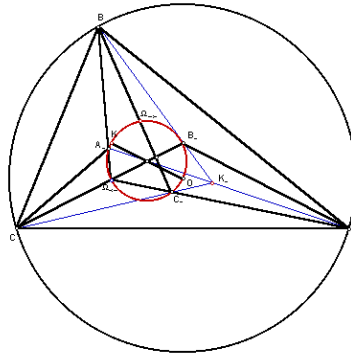

**Exercises**

1. The midpoint of the segment  $\Omega_{\rightarrow}\Omega_{\leftarrow}$  is the *Brocard midpoint* <sup>11</sup>

$$(a^2(b^2 + c^2) : b^2(c^2 + a^2) : c^2(a^2 + b^2)).$$

Show that this is a point on the line  $OK$ .

2. The Brocard circle is the circle through the three points  $A_{-\omega}$ ,  $B_{-\omega}$ , and  $C_{-\omega}$ . It has equation

$$a^2yz + b^2zx + c^2xy - \frac{a^2b^2c^2}{a^2 + b^2 + c^2}(x + y + z) \left( \frac{x}{a^2} + \frac{y}{b^2} + \frac{z}{c^2} \right) = 0.$$

Show that this circle also contains the two Brocard point  $\Omega_{\rightarrow}$  and  $\Omega_{\leftarrow}$ , the circumcenter, and the symmedian point.

3. Let  $XYZ$  be the pedal triangle of  $\Omega_{\rightarrow}$  and  $X'Y'Z'$  be that of  $\Omega_{\leftarrow}$ .

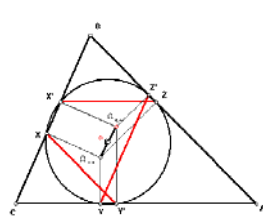

- (a) Find the coordinates of these pedals.
- (b) Show that  $YZ'$  is parallel to  $BC$ .

---

<sup>11</sup>The Brocard midpoint appears in ETC as the point  $X_{39}$ .

(c) The triangle bounded by the three lines  $YZ'$ ,  $ZX'$  and  $XY'$  is homothetic to triangle  $ABC$ . What is the homothetic center? <sup>12</sup>

(d) The triangles  $ZXY$  and  $Y'Z'X'$  are congruent.

## 6.5 Appendix: The circle triad $(A(a), B(b), C(c))$

Consider the circle  $A(a)$ . This circle intersects the line  $AB$  at the two points  $(c + a : -a : 0)$ ,  $(c - a : a : 0)$ , and  $AC$  at  $(a + b : 0 : -a)$  and  $(b - a : 0 : a)$ . It has equation

$$\mathcal{C}_a : a^2yz + b^2zx + c^2xy + (x + y + z)(a^2x + (a^2 - c^2)y + (a^2 - b^2)z) = 0.$$

Similarly, the circles  $B(b)$  and  $C(c)$  have equations

$$\mathcal{C}_b : a^2yz + b^2zx + c^2xy + (x + y + z)((b^2 - c^2)x + b^2y + (b^2 - a^2)z) = 0,$$

and

$$\mathcal{C}_c : a^2yz + b^2zx + c^2xy + (x + y + z)((c^2 - b^2)x + (c^2 - a^2)y + c^2z) = 0.$$

These are called the de Longchamps circles of triangle  $ABC$ . The radical center  $L$  of the circles is the point  $(x : y : z)$  given by

$$a^2x + (a^2 - c^2)y + (a^2 - b^2)z = (b^2 - c^2)x + b^2y + (b^2 - a^2)z = (c^2 - b^2)x + (c^2 - a^2)y + c^2z.$$

Forming the pairwise sums of these expressions we obtain

$$S_A(y + z) = S_B(z + x) = S_C(x + y).$$

From these,

$$y + z : z + x : x + y = \frac{1}{S_A} : \frac{1}{S_B} : \frac{1}{S_C} = S_{BC} : S_{CA} : S_{AB},$$

and

$$x : y : z = S_{CA} + S_{AB} - S_{BC} : S_{AB} + S_{BC} - S_{CA} : S_{BC} + S_{CA} - S_{AB}.$$

This is called the *de Longchamps point* of the triangle. <sup>13</sup> It is the reflection of the orthocenter in the circumcenter, *i.e.*,  $L = 2 \cdot O - H$ .

<sup>12</sup>The symmedian point.

<sup>13</sup>The de Longchamps point appears as the point  $X_{20}$  in ETC.

**Exercises**

1. Show that the intersections of  $\mathcal{C}_b$  and  $\mathcal{C}_c$  are
  - (i) the reflection of  $A$  in the midpoint of  $BC$ , and
  - (ii) the reflection  $A'$  in the perpendicular bisector of  $BC$ .
 What are the coordinates of these points? <sup>14</sup>
2. The circle  $\mathcal{C}_a$  intersects the circumcircle at  $B'$  and  $C'$ .
3. The de Longchamps point  $L$  is the orthocenter of the anticomplementary triangle, and triangle  $A'B'C'$  is the orthic triangle.

**6.5.1 The Steiner point**

The radical axis of the circumcircle and the circle  $\mathcal{C}_a$  is the line

$$a^2x + (a^2 - c^2)y + (a^2 - b^2)z = 0.$$

This line intersects the side line  $BC$  at point

$$A' = \left( 0 : \frac{1}{c^2 - a^2} : \frac{1}{a^2 - b^2} \right).$$

Similarly, the radical axis of  $\mathcal{C}_b$  has  $b$ -intercept

$$B' = \left( \frac{1}{b^2 - c^2} : 0 : \frac{1}{a^2 - b^2} \right),$$

and that of  $\mathcal{C}_c$  has  $c$ -intercept

$$C' = \left( \frac{1}{b^2 - c^2} : \frac{1}{c^2 - a^2} : 0 \right).$$

These three points  $A'$ ,  $B'$ ,  $C'$  are the traces of the point with coordinates

$$\left( \frac{1}{b^2 - c^2} : \frac{1}{c^2 - a^2} : \frac{1}{a^2 - b^2} \right).$$

This is a point on the circumcircle, called the *Steiner point*. <sup>15</sup>

---

<sup>14</sup> $(-1 : 1 : 1)$  and  $A' = (-a^2 : b^2 - c^2 : c^2 - b^2)$ .

<sup>15</sup>This point appears as  $X_{99}$  in ETC.

**Exercises**

1. The antipode of the Steiner point on the circumcircle is called the *Tarry point*. Calculate its coordinates.<sup>16</sup>
2. Reflect the vertices  $A, B, C$  in the centroid  $G$  to form the points  $A', B', C'$  respectively. Use the **five-point conic** command to construct the conic through  $A, B, C, A', B', C'$ . This is the *Steiner circum-ellipse*. Apart from the vertices, it intersects the circumcircle at the Steiner point.
3. Use the **five-point conic** command to construct the conic through the vertices of triangle  $ABC$ , its centroid, and orthocenter. This is a rectangular hyperbola called the *Kiepert hyperbola* which intersect the circumcircle, apart from the vertices, at the Tarry point.

---

<sup>16</sup> $(\frac{1}{a^2(b^2+c^2)-(b^4+c^4)} : \dots : \dots)$ . The Tarry point appears the point  $X_{98}$  in ETC.

# Chapter 7

## Circles III

### 7.1 The distance formula

Let  $P = uA + vB + wC$  and  $Q = u'A + v'B + w'C$  be given in absolute barycentric coordinates. The distance between them is given by

$$PQ^2 = S_A(u - u')^2 + S_B(v - v')^2 + S_C(w - w')^2$$

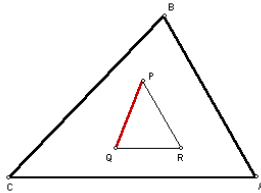

*Proof.* Through  $P$  and  $Q$  draw lines parallel to  $AB$  and  $AC$  respectively, intersecting at  $R$ . The barycentric coordinates of  $R$  can be determined in two ways.  $R = P + h(B - C) = Q + k(A - C)$  for some  $h$  and  $k$ . It follows that  $R = uA + (v + h)B + (w - h)C = (u' + k)A + v'B + (w' - k)C$ , from which  $h = -(v - v)'$  and  $k = u - u'$ . Applying the law of cosines to triangle  $PQR$ , we have

$$\begin{aligned} PQ^2 &= (ha)^2 + (kb)^2 - 2(ha)(kb) \cos C \\ &= h^2 a^2 + k^2 b^2 - 2hk S_C \\ &= (S_B + S_C)(v - v')^2 + (S_C + S_A)(u - u')^2 + 2(u - u')(v - v') S_C \\ &= S_A(u - u')^2 + S_B(v - v')^2 \\ &\quad + S_C[(u - u')^2 + 2(u - u')(v - v') + (v - v')^2]. \end{aligned}$$



The result follows since

$$(u - u') + (v - v') = (u + v) - (u' + v') = (1 - w) - (1 - w') = -(w - w').$$

### The distance formula in homogeneous coordinates

If  $P = (x : y : z)$  and  $Q = (u : v : w)$ , the distance between  $P$  and  $Q$  is given by

$$|PQ|^2 = \frac{1}{(u + v + w)^2(x + y + z)^2} \sum_{\text{cyclic}} S_A((v + w)x - u(y + z))^2.$$

### Exercises

1. The distance from  $P = (x : y : z)$  to the vertices of triangle  $ABC$  are given by

$$\begin{aligned} AP^2 &= \frac{c^2y^2 + 2S_Ayz + b^2z^2}{(x + y + z)^2}, \\ BP^2 &= \frac{a^2z^2 + 2S_Bzx + c^2x^2}{(x + y + z)^2}, \\ CP^2 &= \frac{b^2x^2 + 2S_Cxy + a^2y^2}{(x + y + z)^2}. \end{aligned}$$

2. The distance between  $P = (x : y : z)$  and  $Q = (u : v : w)$  can be written as

$$|PQ|^2 = \frac{1}{x + y + z} \cdot \left( \sum_{\text{cyclic}} \frac{c^2v^2 + 2S_Avw + b^2w^2}{(u + v + w)^2} x \right) - \frac{a^2yz + b^2zx + c^2xy}{(x + y + z)^2}.$$

3. Compute the distance between the incenter and the nine-point center  $N = (S^2 + S_A : S^2 + S_B : S^2 + S_C)$ . Deduce Feuerbach's theorem by showing that this is  $\frac{R}{2} - r$ . Find the coordinates of the Feuerbach point  $F$  as the point dividing  $NI$  externally in the ratio  $R : -2r$ .

## 7.2 Circle equations

### 7.2.1 Equation of circle with center $(u : v : w)$ and radius $\rho$ :

$$a^2yz + b^2zx + c^2xy - (x + y + z) \sum_{\text{cyclic}} \left( \frac{c^2v^2 + 2S_Avw + b^2w^2}{(u + v + w)^2} - \rho^2 \right) x = 0.$$

### 7.2.2 The power of a point with respect to a circle

Consider a circle  $\mathcal{C} := O(\rho)$  and a point  $P$ . By the theorem on intersecting chords, for any line through  $P$  intersecting  $\mathcal{C}$  at two points  $X$  and  $Y$ , the product  $|PX||PY|$  of *signed* lengths is constant. We call this product the *power* of  $P$  with respect to  $\mathcal{C}$ . By considering the diameter through  $P$ , we obtain  $|OP|^2 - \rho^2$  for the power of a point  $P$  with respect to  $O(\rho)$ .

### 7.2.3 Proposition

Let  $p, q, r$  be the powers of  $A, B, C$  with respect to a circle  $\mathcal{C}$ .

(1) The equation of the circle is

$$a^2yz + b^2zx + c^2xy - (x + y + z)(px + qy + rz) = 0.$$

(2) The center of the circle is the point

$$(a^2S_A + S_B(r-p) - S_C(p-q) : b^2S_B + S_C(p-q) - S_A(r-p) : c^2S_C + S_A(q-r) - S_B(r-p)).$$

(3) The radius  $\rho$  of the circle is given by

$$\rho^2 = \frac{a^2b^2c^2 - 2(a^2S_{Ap} + b^2S_{Bq} + c^2S_{Cr}) + S_A(q-r)^2 + S_B(r-p)^2 + S_C(p-q)^2}{4S^2}.$$

### Exercises

- Let  $X, Y, Z$  be the pedals of  $A, B, C$  on their opposite sides. The pedals of  $X$  on  $CA$  and  $AB$ ,  $Y$  on  $AB$ ,  $BC$ , and  $Z$  on  $CA$ ,  $BC$  are on a circle. Show that the equation of the circle is <sup>1</sup>

$$a^2yz + b^2zx + c^2xy - \frac{1}{4R^2}(x + y + z)(S_{AA}x + S_{BB}y + S_{CC}z) = 0.$$

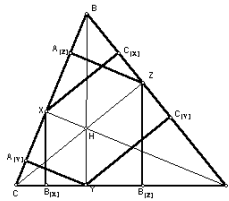

<sup>1</sup>This is called the *Taylor circle* of triangle  $ABC$ . Its center is the point  $X_{389}$  in ETC. This point is also the intersection of the three lines through the midpoint of each side of the *orthic triangle* perpendicular to the corresponding side of  $ABC$ .

2. Let  $P = (u : v : w)$ .
- Find the equations of the circles  $ABY$  and  $ACZ$ , and the coordinates of their second intersection  $A'$ .
  - Similarly define  $B'$  and  $C'$ . Show that triangle  $A'B'C'$  is perspective with  $ABC$ . Identify the perspector.<sup>2</sup>

### 7.3 Radical circle of a triad of circles

Consider three circles with equations

$$a^2yz + b^2zx + c^2xy - (x + y + z)(p_1x + q_1y + r_1z) = 0, \quad i = 1, 2, 3.$$

#### 7.3.1 Radical center

The *radical center*  $P$  is the point with equal powers with respect to the three circles. Its coordinates are given by the solutions of the system of equations.

$$p_1x + q_1y + r_1z = p_2x + q_2y + r_2z = p_3x + q_3y + r_3z.$$

Explicitly, if we write

$$M = \begin{pmatrix} p_1 & q_1 & r_1 \\ p_2 & q_2 & r_2 \\ p_3 & q_3 & r_3 \end{pmatrix},$$

then,  $P = (u : v : w)$  with<sup>3</sup>

$$u = \begin{pmatrix} 1 & q_1 & r_1 \\ 1 & q_2 & r_2 \\ 1 & q_3 & r_3 \end{pmatrix}, \quad v = \begin{pmatrix} p_1 & 1 & r_1 \\ p_2 & 1 & r_2 \\ p_3 & 1 & r_3 \end{pmatrix}, \quad w = \begin{pmatrix} p_1 & q_1 & 1 \\ p_2 & q_2 & 1 \\ p_3 & q_3 & 1 \end{pmatrix}.$$

#### 7.3.2 Radical circle

There is a circle orthogonal to each of the circles  $\mathcal{C}_i$ ,  $i = 1, 2, 3$ . The center is the radical center  $P$  above, and its square radius is the *negative* of the common power of  $P$  with respect to the circles, *i.e.*,

$$\frac{a^2vw + b^2wu + c^2uv}{(u + v + w)^2} - \frac{\det M}{u + v + w}.$$

<sup>2</sup> $(\frac{a^2}{v+w} : \dots : \dots)$ . See Tatiana Emelyanov, Hyacinthos, message 3309, 7/27/01.

<sup>3</sup>Proof:  $p_1u + q_1v + r_1w = p_2u + q_2v + r_2w = p_3u + q_3v + r_3w = \det M$ .

This circle, which we call the *radical circle* of the given triad, has equation

$$\sum_{\text{cyclic}} (c^2v + b^2w)x^2 + 2S_A uyz - \det(M)(x + y + z)^2 = 0.$$

In standard form, it is

$$a^2yz + b^2zx + c^2xy - \frac{1}{u + v + w} \cdot (x + y + z) \left( \sum_{\text{cyclic}} (c^2v + b^2w - \det(M))x \right) = 0.$$

The radical circle is real if and only if

$$(u + v + w)(p_i u + q_i v + r_i w) - (a^2vw + b^2wu + c^2uv) \geq 0$$

for any  $i = 1, 2, 3$ .

### 7.3.3 The excircles

The radical center of the excircles is the point  $P = (u : v : w)$  given by

$$\begin{aligned} u &= \begin{pmatrix} 1 & (s-c)^2 & (s-b)^2 \\ 1 & s^2 & (s-a)^2 \\ 1 & (s-a)^2 & s^2 \end{pmatrix} = \begin{pmatrix} 1 & (s-c)^2 & (s-a)^2 \\ 0 & c(a+b) & -c(a-b) \\ 0 & b(c-a) & b(c+a) \end{pmatrix} \\ &= bc(a+b)(c+a) + bc(a-b)(c-a) = 2abc(b+c), \end{aligned}$$

and, likewise,  $v = 2abc(c+a)$  and  $w = 2abc(a+b)$ . This is the point  $(b+c : c+a : a+b)$ , called the *Spieker center*. It is the incenter of the medial triangle.

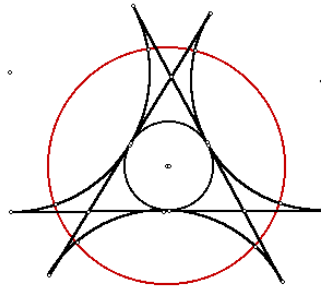

Since, with  $(u, v, w) = (b+c, c+a, a+b)$ ,

$$(u + v + w)(s^2u + (s-c)^2v + (s-b)^2w) - (a^2vw + b^2wu + c^2uv)$$

$$\begin{aligned}
&= (a+b+c)(2abc + \sum a^3 + \sum a^2(b+c)) - (a+b+c)(abc + \sum a^3) \\
&= (a+b+c)(abc + \sum a^2(b+c)),
\end{aligned}$$

the square radius of the orthogonal circle is

$$\frac{abc + \sum a^2(b+c)}{a+b+c} = \dots = \frac{1}{4}(r^2 + s^2).$$

The equation of the radical circle can be written as

$$\sum_{\text{cyclic}} (s-b)(s-c)x^2 + asyz = 0.$$

### 7.3.4 The de Longchamps circle

The radical center  $L$  of the circle triad  $(A(a), B(b), C(c))$  is the point  $(x : y : z)$  given by

$$a^2x + (a^2 - c^2)y + (a^2 - b^2)z = (b^2 - c^2)x + b^2y + (b^2 - a^2)z = (c^2 - b^2)x + (c^2 - a^2)y + c^2z.$$

Forming the pairwise sums of these expressions we obtain

$$S_A(y+z) = S_B(z+x) = S_C(x+y).$$

From these,

$$y+z : z+x : x+y = \frac{1}{S_A} : \frac{1}{S_B} : \frac{1}{S_C} = S_{BC} : S_{CA} : S_{AB},$$

and

$$x : y : z = S_{CA} + S_{AB} - S_{BC} : S_{AB} + S_{BC} - S_{CA} : S_{BC} + S_{CA} - S_{AB}.$$

This is called the *de Longchamps point* of the triangle.<sup>4</sup> It is the reflection of the orthocenter in the circumcenter, *i.e.*,  $L = 2 \cdot O - H$ . The de Longchamps circle is the radical circle of the triad  $A(a)$ ,  $B(b)$  and  $C(c)$ . It has equation

$$a^2yz + b^2zx + c^2xy - (x+y+z)(a^2x + b^2y + c^2z) = 0.$$

This circle is real if and only if triangle  $ABC$  is obtuse - angled.

It is also orthogonal to the triad of circles  $(D(A), E(B), F(C))$ .<sup>5</sup>

<sup>4</sup>The de Longchamps point appears as the point  $X_{20}$  in ETC.

<sup>5</sup>G. de Longchamps, Sur un nouveau cercle remarquable du plan d'un triangle, *Journal de Math. Spéciales*, 1886, pp. 57 - 60, 85 - 87, 100 - 104, 126 - 134.

### Exercises

1. The radical center of the triad of circles  $A(R_a)$ ,  $B(R_b)$ , and  $C(R_c)$  is the point

$$2S^2 \cdot O - a^2 R_a^2 (A - A_H) - b^2 R_b^2 (B - B_H) - c^2 R_c^2 (C - C_H).$$

## 7.4 The Lucas circles <sup>6</sup>

Consider the square  $A_b A_c A'_c A'_b$  inscribed in triangle  $ABC$ , with  $A_b, A_c$  on  $BC$ . Since this square can be obtained from the square erected externally on  $BC$  via the homothety  $h(A, \frac{S}{a^2+S})$ , the equation of the circle  $\mathcal{C}_A$  through  $A, A'_b$  and  $A'_c$  can be easily written down:

$$\mathcal{C}_A : \quad a^2 yz + b^2 zx + c^2 xy - \frac{a^2}{a^2+S} \cdot (x+y+z)(c^2 y + b^2 z) = 0.$$

Likewise if we construct inscribed squares  $B_c B_a B'_a B'_c$  and  $C_a C_b C'_b C'_a$  on the other two sides, the corresponding Lucas circles are

$$\mathcal{C}_B : \quad a^2 yz + b^2 zx + c^2 xy - \frac{b^2}{b^2+S} \cdot (x+y+z)(c^2 x + a^2 z) = 0,$$

and

$$\mathcal{C}_C : \quad a^2 yz + b^2 zx + c^2 xy - \frac{c^2}{c^2+S} \cdot (x+y+z)(b^2 x + a^2 y) = 0.$$

The coordinates of the radical center satisfy the equations

$$\frac{a^2(c^2 y + b^2 z)}{a^2+S} = \frac{b^2(a^2 z + c^2 x)}{b^2+S} = \frac{c^2(b^2 x + a^2 y)}{c^2+S}.$$

Since this can be rewritten as

$$\frac{y}{b^2} + \frac{z}{c^2} : \frac{z}{c^2} + \frac{x}{a^2} : \frac{x}{a^2} + \frac{y}{b^2} = a^2 + S : b^2 + S : c^2 + S,$$

it follows that

$$\frac{x}{a^2} : \frac{y}{b^2} : \frac{z}{c^2} = b^2 + c^2 - a^2 + S : c^2 + a^2 - b^2 + S : a^2 + b^2 - c^2 + S,$$

---

<sup>6</sup>A.P. Hatzipolakis and P. Yiu, The Lucas circles, *Amer. Math. Monthly*, 108 (2001) 444 – 446.

and the radical center is the point

$$(a^2(2S_A + S) : b^2(2S_B + S) : c^2(2S_C + S)).$$

The three Lucas circles are mutually tangent to each other, the points of tangency being

$$\begin{aligned} A' &= (a^2 S_A : b^2(S_B + S) : c^2(S_C + S)), \\ B' &= (b^2(S_A + S) : b^2 S_B : c^2(S_C + S)), \\ C' &= (a^2(S_A + S) : b^2(S_B + S) : c^2 S_C). \end{aligned}$$

### Exercises

1. These point of tangency form a triangle perspective with  $ABC$ . Calculate the coordinates of the perspector.<sup>7</sup>

## 7.5 Appendix: More triads of circles

1. (a) Construct the circle tangent to the circumcircle *internally* at  $A$  and also to the side  $BC$ .  
 (b) Find the coordinates of the point of tangency with the side  $BC$ .  
 (c) Find the equation of the circle.<sup>8</sup>  
 (d) Similarly, construct the two other circles, each tangent internally to the circumcircle at a vertex and also to the opposite side.  
 (e) Find the coordinates of the radical center of the three circles.<sup>9</sup>
2. Construct the three circles each tangent to the circumcircle *externally* at a vertex and also to the opposite side. Identify the radical center, which is a point on the circumcircle.<sup>10</sup>
3. Let  $X, Y, Z$  be the traces of a point  $P$  on the side lines  $BC, CA, AB$  of triangle  $ABC$ .  
 (a) Construct the three circles, each passing through a vertex of  $ABC$  and tangent to opposite side at the trace of  $P$ .

<sup>7</sup> $(a^2(S_A + S) : b^2(S_B + S) : c^2(S_C + S))$ . This point appears in ETC as  $X_{371}$ , and is called the Kenmotu point. It is the isogonal conjugate of the Vecten point  $(\frac{1}{S_A+S} : \frac{1}{S_B+S} : \frac{1}{S_C+S})$ .

<sup>8</sup> $a^2yz + b^2zx + c^2xy - \frac{a^2}{(b+c)^2}(x+y+z)(c^2y + b^2z) = 0$ .

<sup>9</sup> $(a^2(a^2 + a(b+c) - bc) : \dots : \dots)$ .

<sup>10</sup> $\frac{a^2}{b-c} : \frac{b^2}{c-a} : \frac{c^2}{a-b}$ .

- (b) Find the equations of these three circles.
- (c) The radical center of these three circles is a point independent of  $P$ . What is this point?
4. Find the equations of the three circles each through a vertex and the traces of the incenter and the Gergonne point on the opposite side. What is the radical center of the triad of circles? <sup>11</sup>
5. Let  $P = (u : v : w)$ . Find the equations of the three circles with the cevian segments  $AA_P$ ,  $BB_P$ ,  $CC_P$  as diameters. What is the radical center of the triad? <sup>12</sup>
6. Given a point  $P$ . The perpendicular from  $P$  to  $BC$  intersects  $CA$  at  $Y_a$  and  $AB$  at  $Z_a$ . Similarly define  $Z_b$ ,  $X_b$ , and  $X_c$ ,  $Y_c$ . Show that the circles  $AY_aZ_a$ ,  $BZ_bX_b$  and  $CX_cY_c$  intersect at a point on the circumcircle of  $ABC$ . <sup>13</sup>

### Exercises

1. Consider triangle  $ABC$  with three circles  $A(R_a)$ ,  $B(R_b)$ , and  $C(R_c)$ . The circle  $B(R_b)$  intersects  $AB$  at  $Z_{a+} = (R_b : c - R_b : 0)$  and  $Z_{a-} = (-R_b : c + R_b : 0)$ . Similarly,  $C(R_c)$  intersects  $AC$  at  $Y_{a+} = (R_c : 0 : b - R_c)$  and  $Y_{a-} = (-R_c : 0 : b + R_c)$ . <sup>14</sup>
- (a) Show that the centers of the circles  $AY_{a+}Z_{a+}$  and  $AY_{a-}Z_{a-}$  are symmetric with respect to the circumcenter  $O$ .
- (b) Find the equations of the circles  $AY_{a+}Z_{a+}$  and  $AY_{a-}Z_{a-}$ . <sup>15</sup>
- (c) Show that these two circles intersect at

$$Q = \left( \frac{-a^2}{bR_b - cR_c} : \frac{b}{R_b} : \frac{-c}{R_c} \right)$$

on the circumcircle.

<sup>11</sup>The external center of similitude of the circumcircle and incircle.

<sup>12</sup>Floor van Lamoen, Hyacinthos, message 214, 1/24/00.

<sup>13</sup>If  $P = (u; v : w)$ , this intersection is  $(\frac{a^2}{vS_B - wS_C} : \frac{b^2}{wS_C - uS_A} : \frac{c^2}{uS_A - vS_B})$ ; it is the infinite point of the line perpendicular to  $HP$ . A.P. Hatzipolakis and P. Yiu, Hyacinthos, messages 1213, 1214, 1215, 8/17/00.

<sup>14</sup>A.P. Hatzipolakis, Hyacinthos, message 3408, 8/10/01.

<sup>15</sup> $a^2yz + b^2zx + c^2xy - \epsilon(x + y + z)(c \cdot R_by + b \cdot R_cz) = 0$  for  $\epsilon = \pm 1$ .



- (d) Find the equations of the circles  $AY_{a+}Z_{a-}$  and  $AY_{a-}Z_{a+}$  and show that they intersect at

$$Q' = \left( \frac{-a^2}{bR_b + cR_c} : \frac{b}{R_b} : \frac{c}{R_c} \right)$$

on the circumcircle.<sup>16</sup>

- (e) Show that the line  $QQ'$  passes through the points  $(-a^2 : b^2 : c^2)$  and<sup>17</sup>

$$P = (a^2(-a^2R_a^2 + b^2R_b^2 + c^2R_c^2) : \dots : \dots).$$

- (f) If  $W$  is the radical center of the three circles  $A(R_a)$ ,  $B(R_b)$ , and  $C(R_c)$ , then  $P = (1 - t)O + t \cdot W$  for

$$t = \frac{2a^2b^2c^2}{R_a^2a^2S_A + R_b^2b^2S_B + R_c^2c^2S_C}.$$

- (g) Find  $P$  if  $R_a = a$ ,  $R_b = b$ , and  $R_c = c$ .<sup>18</sup>  
 (h) Find  $P$  if  $R_a = s - a$ ,  $R_b = s - b$ , and  $R_c = s - c$ .<sup>19</sup>  
 (i) If the three circles  $A(R_a)$ ,  $B(R_b)$ , and  $C(R_c)$  intersect at  $W = (u : v : w)$ , then

$$P = (a^2(b^2c^2u^2 - a^2S_Avw + b^2S_Bwu + c^2S_Cwv) : \dots : \dots).$$

- (j) Find  $P$  if  $W$  is the incenter.<sup>20</sup>  
 (k) If  $W = (u : v : w)$  is on the circumcircle, then  $P = Q = Q' = W$ .

<sup>16</sup>  $a^2yz + b^2zx + c^2xy - \epsilon(x + y + z)(c \cdot R_by - b \cdot R_cz) = 0$  for  $\epsilon = \pm 1$ .

<sup>17</sup>  $QQ' : (b^2R_b^2 - c^2R_c^2)x + a^2(R_by - R_cz) = 0$ .

<sup>18</sup>  $(a^2(b^4 + c^4 - a^4) : b^2(c^4 + a^4 - b^4) : c^2(a^4 + b^4 - c^4))$ . This point appears as  $X_{22}$  in ETC.

<sup>19</sup>  $(\frac{a^2(a^2 - 2a(b+c) + (b^2 + c^2))}{s-a} : \dots : \dots)$ . This point does not appear in the current edition of ETC.

<sup>20</sup>  $(\frac{a^2}{s-a} : \frac{b^2}{s-b} : \frac{c^2}{s-c})$ .

## Chapter 8

# Some Basic Constructions

### 8.1 Barycentric product

Let  $X_1, X_2$  be two points on the line  $BC$ , distinct from the vertices  $B, C$ , with homogeneous coordinates  $(0 : y_1 : z_1)$  and  $(0 : y_2 : z_2)$ . For  $i = 1, 2$ , complete parallelograms  $AK_iX_iH_i$  with  $K_i$  on  $AB$  and  $H_i$  on  $AC$ . The coordinates of the points  $H_i, K_i$  are

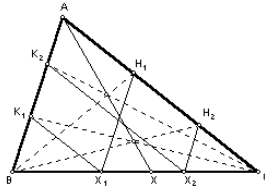

$$\begin{aligned} H_1 &= (y_1 : 0 : z_1), & K_1 &= (z_1 : y_1 : 0); \\ H_2 &= (y_2 : 0 : z_2), & K_2 &= (z_2 : y_2 : 0). \end{aligned}$$

From these,

$$\begin{aligned} BH_1 \cap CK_2 &= (y_1z_2 : y_1y_2 : z_1z_2), \\ BH_2 \cap CK_1 &= (y_2z_1 : y_1y_2 : z_1z_2). \end{aligned}$$

Both of these points have  $A$ -trace  $(0 : y_1y_2 : z_1z_2)$ . This means that the line joining these intersections passes through  $A$ .

Given two points  $P = (x : y : z)$  and  $Q = (u : v : w)$ , the above construction (applied to the traces on each side line) gives the traces of the

point with coordinates  $(xu : yv : zw)$ . We shall call this point the *barycentric product* of  $P$  and  $Q$ , and denote it by  $P \cdot Q$ .

In particular, the *barycentric square* of a point  $P = (u : v : w)$ , with coordinates  $(u^2 : v^2 : w^2)$  can be constructed as follows:

- (1) Complete a parallelogram  $AB_aA_PC_a$  with  $B_a$  on  $CA$  and  $C_a$  on  $AB$ .
- (2) Construct  $BB_a \cap CC_a$ , and join it to  $A$  to intersect  $BC$  at  $X$ .
- (3) Repeat the same constructions using the traces on  $CA$  and  $AB$  respectively to obtain  $Y$  on  $CA$  and  $Z$  on  $AB$ .

Then,  $X, Y, Z$  are the traces of the barycentric square of  $P$ .

### 8.1.1 Examples

(1) The Clawson point  $(\frac{a}{s_A} : \frac{b}{s_B} : \frac{c}{s_C})$  can be constructed as the barycentric product of the incenter and the orthocenter.

(2) The symmedian point can be constructed as the barycentric square of the incenter.

(3) If  $P = (u + v + w)$  is an infinite point, its barycentric square can also be constructed as the barycentric product of  $P$  and its inferior  $(v + w : w + u : u + v)$ :

$$\begin{aligned} P^2 &= (u^2 : v^2 : w^2) \\ &= (-u(v + w) : -v(w + u) : -w(u + v)) \\ &= (u : v : w) \cdot (v + w : w + u : u + v). \end{aligned}$$

### 8.1.2 Barycentric square root

Let  $P = (u : v : w)$  be a point in the interior of triangle  $ABC$ , the barycentric square root  $\sqrt{P}$  is the point  $Q$  in the interior such that  $Q^2 = P$ . This can be constructed as follows.

- (1) Construct the circle with  $BC$  as diameter.
- (2) Construct the perpendicular to  $BC$  at the trace  $A_P$  to intersect the circle at  $X$ .<sup>1</sup> Bisect angle  $BXC$  to intersect  $BC$  at  $X'$ .
- (3) Similarly obtain  $Y'$  on  $CA$  and  $Z'$  on  $AB$ .

The points  $X', Y', Z'$  are the traces of the barycentric square root of  $P$ .

---

<sup>1</sup>It does not matter which of the two intersections is chosen.

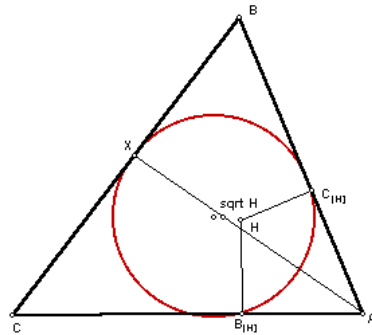

**The square root of the orthocenter**

Let  $ABC$  be an acute angled triangle so that the orthocenter  $H$  is an interior point. Let  $X$  be the  $A$ -trace of  $\sqrt{H}$ . The circle through the pedals  $B_{[H]}$ ,  $C_{[H]}$  and  $X$  is tangent to the side  $BC$ .

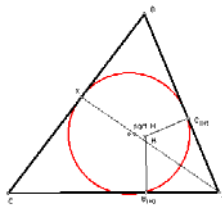

**8.1.3 Exercises**

1. Construct a point whose distances from the side lines are proportional to the radii of the excircles. <sup>2</sup>
2. Find the equation of the circle through  $B$  and  $C$ , tangent (internally) to incircle. Show that the point of tangency has coordinates

$$\left( \frac{a^2}{s-a} : \frac{(s-c)^2}{s-b} : \frac{(s-b)^2}{s-c} \right).$$

Construct this circle by making use of the barycentric “third power” of the Gergonne point.

3. Construct the square of an infinite point.

---

<sup>2</sup>This has coordinates  $(\frac{a}{s-a} : \dots : \dots)$  and can be constructed as the barycentric product of the incenter and the Gergonne point.

4. A circle is tangent to the side  $BC$  of triangle  $ABC$  at the  $A$ -trace of a point  $P = (u : v : w)$  and internally to the circumcircle at  $A'$ . Show that the line  $AA'$  passes through the point  $(au : bv : vw)$ .

Make use of this to construct the three circles each tangent internally to the circumcircle and to the side lines at the traces of  $P$ .

5. Two circles each passing through the incenter  $I$  are tangent to  $BC$  at  $B$  and  $C$  respectively. A circle ( $J_a$ ) is tangent externally to each of these, and to  $BC$  at  $X$ . Similarly define  $Y$  and  $Z$ . Show that  $XYZ$  is perspective with  $ABC$ , and find the perspector.<sup>3</sup>

6. Let  $P_1 = (f_1 : g_1 : h_1)$  and  $P_2 = (f_2 : g_2 : h_2)$  be two given points. Denote by  $X_i, Y_i, Z_i$  the traces of these points on the sides of the reference triangle  $ABC$ .

- (a) Find the coordinates of the intersections  $X_+ = BY_1 \cap CZ_2$  and  $X_- = BY_2 \cap CZ_1$ .<sup>4</sup>

- (b) Find the equation of the line  $X_+X_-$ .<sup>5</sup>

- (c) Similarly define points  $Y_+, Y_-, Z_+$  and  $Z_-$ . Show that the three lines  $X_+X_-, Y_+Y_-$ , and  $Z_+Z_-$  intersect at the point

$$(f_1 f_2 (g_1 h_2 + h_1 g_2) : g_1 g_2 (h_1 f_2 + f_1 h_2) : h_1 h_2 (f_1 g_2 + g_1 f_2)).$$

## 8.2 Harmonic associates

The *harmonic associates* of a point  $P = (u : v : w)$  are the points

$$A^P = (-u : v : w), \quad B^P = (u : -v : w), \quad C^P = (u : v : -w).$$

The point  $A^P$  is the harmonic conjugate of  $P$  with respect to the cevian segment  $AA_P$ , *i.e.*,

$$AP : PA_P = -AA^P : -A^P A_P;$$

similarly for  $B^P$  and  $C^P$ . The triangle  $A^P C^P B^P$  is called the *precevian triangle* of  $P$ . This terminology is justified by the fact that  $ABC$  is the cevian triangle  $P$  in  $A^P B^P C^P$ . It is also convenient to regard  $P, A^P, B^P, C^P$  as a

<sup>3</sup>The barycentric square root of  $(\frac{a}{s-a} : \frac{b}{s-b} : \frac{c}{s-c})$ . See Hyacinthos, message 3394, 8/9/01.

<sup>4</sup> $X_+ = f_1 f_2 : f_1 g_2 : h_1 f_2$ ;  $X_- = f_1 f_2 : g_1 f_2 : f_1 h_2$ .

<sup>5</sup> $(f_1^2 g_2 h_2 - f_2^2 g_1 h_1)x - f_1 f_2 (f_1 h_2 - h_1 f_2)y + f_1 f_2 (g_1 f_2 - f_1 g_2)z = 0..$

harmonic quadruple in the sense that any three of the points constitute the harmonic associates of the remaining point.

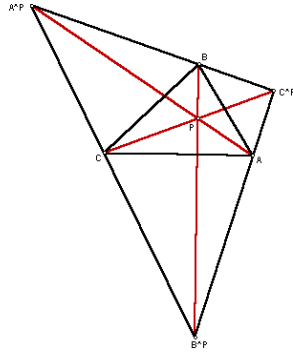

### Examples

(1) The harmonic associates of the centroid, can be constructed as the intersection of the parallels to the side lines through their opposite vertices. They form the *superior triangle* of  $ABC$ .

(2) The harmonic associates of the incenter are the excenters.

(3) If  $P$  is an interior point with square root  $Q$ . The harmonic associates of  $Q$  can also be regarded as square roots of the same point.

### 8.2.1 Superior and inferior triangles

The precevian triangle of the centroid is called the *superior triangle* of  $ABC$ . If  $P = (u : v : w)$ , the point  $(-u + v + w : u - v + w : u + v - w)$ , which divides  $PG$  in the ratio  $3 : -2$ , has coordinates  $(u : v : w)$  relative to the superior triangle, and is called the *superior* of  $P$ .

Along with the superior triangle, we also consider the cevian triangle of  $G$  as the *inferior triangle*. The point  $(v + w : w + u : u + v)$ , which divides  $PG$  in the ratio  $3 : -1$ , has coordinates  $(u : v : w)$  relative to the inferior triangle, and is called the *inferior* of  $P$ .

### Exercises

1. If  $P$  is the centroid of its precevian triangle, show that  $P$  is the centroid of triangle  $ABC$ .

- The incenter and the excenters form the only harmonic quadruple which is also orthocentric, *i.e.*, each one of them is the orthocenter of the triangle formed by the remaining three points.

### 8.3 Cevian quotient

#### Theorem

For any two points  $P$  and  $Q$  not on the side lines of  $ABC$ , the cevian triangle of  $P$  and precevian triangle of  $Q$  are perspective. If  $P = (u : v : w)$  and  $Q = (x : y : z)$ , the perspector is the point

$$P/Q = \left( x \left( -\frac{x}{u} + \frac{y}{v} + \frac{z}{w} \right) : y \left( \frac{x}{u} - \frac{y}{v} + \frac{z}{w} \right) : z \left( \frac{x}{u} + \frac{y}{v} - \frac{z}{w} \right) \right).$$

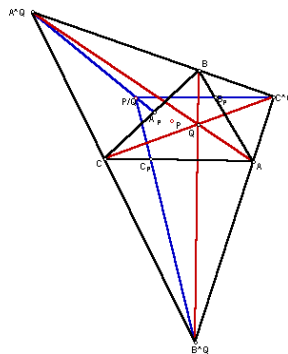

#### Proposition

$$P/(P/Q) = Q.$$

*Proof.* Direct verification.

This means that if  $P/Q = Q'$ , then  $P/Q' = Q$ .

#### Exercises

- Show that  $P/(P \cdot P) = P \cdot (G/P)$ .
- Identify the following cevian quotients.

$P$	$Q$	$P/Q$
incenter	centroid	
incenter	symmedian point	
incenter	Feuerbach point	
centroid	circumcenter	
centroid	symmedian point	
centroid	Feuerbach point	
orthocenter	symmedian point	
orthocenter	$(a(b - c) : \dots : \dots)$	
Gergonne point	incenter	

3. Let  $P = (u : v : w)$  and  $Q = (u' : v' : w')$  be two given points. If

$$X = B_P C_P \cap A A_Q, \quad Y = C_P A_P \cap B B_Q, \quad Z = A_P B_P \cap C C_Q,$$

show that  $A_P X$ ,  $B_P Y$  and  $C_P Z$  are concurrent. Calculate the coordinates of the intersection. <sup>6</sup>

### 8.4 The Brocardians

The Brocardians of a point  $P = (u : v : w)$  are the points

$$P_{\rightarrow} = \left( \frac{1}{w} : \frac{1}{u} : \frac{1}{v} \right) \quad \text{and} \quad P_{\leftarrow} = \left( \frac{1}{v} : \frac{1}{w} : \frac{1}{u} \right).$$

#### Construction of Brocardian points

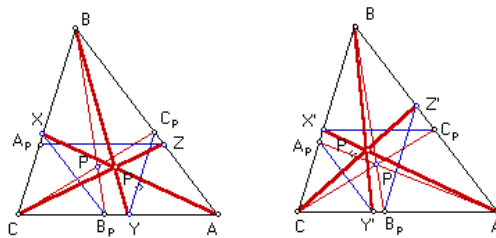

<sup>6</sup> $(u u'(v w' + w v') : \dots : \dots)$ ; see J.H. Tummers, Points remarquables, associées à un triangle, *Nieuw Archief voor Wiskunde* IV 4 (1956) 132 – 139. O. Bottema, Une construction par rapport à un triangle, *ibid.*, IV 5 (1957) 68 – 70, has subsequently shown that this is the pole of the line  $PQ$  with respect to the circumconic through  $P$  and  $Q$ .



**Examples**

(1) The Brocard points  $\Omega_{\rightarrow}$  and  $\Omega_{\leftarrow}$  are the Brocardians of the symmedian point  $K$ .

(2) The Brocardians of the incenter are called the *Jerabek points*:

$$I_{\rightarrow} = \left( \frac{1}{c} : \frac{1}{a} : \frac{1}{b} \right) \quad \text{and} \quad I_{\leftarrow} = \left( \frac{1}{b} : \frac{1}{c} : \frac{1}{a} \right).$$

The *oriented* parallels through  $I_{\rightarrow}$  to  $BC$ ,  $CA$ ,  $AB$  intersect the sides  $CA$ ,  $BC$ ,  $AB$  at  $Y$ ,  $Z$ ,  $X$  such that  $I_{\rightarrow}Y = I_{\rightarrow}Z = I_{\rightarrow}X$ . Likewise, the parallels through  $I_{\leftarrow}$  to  $BC$ ,  $CA$ ,  $AB$  intersect the sides  $AB$ ,  $BC$ ,  $CA$  at  $Z$ ,  $X$ ,  $Y$  such that  $I_{\leftarrow}Z = I_{\leftarrow}X = I_{\leftarrow}Y$ . These 6 segments have length  $\ell$  satisfying  $\frac{1}{\ell} = \frac{1}{a} + \frac{1}{b} + \frac{1}{c}$ , one half of the length of the equal parallelians drawn through  $(-\frac{1}{a} + \frac{1}{b} + \frac{1}{c} : \dots : \dots)$ .

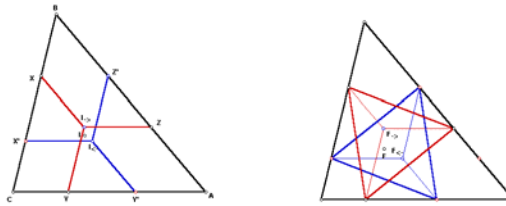

(3) If oriented parallels are drawn through the forward Brocardian point of the (positive) Fermat point  $F_+$ , and intersect the sides  $CA$ ,  $AB$ ,  $BC$  at  $X$ ,  $Y$ ,  $Z$  respectively, then the triangle  $XYZ$  is equilateral.<sup>7</sup>

<sup>7</sup>S. Bier, Equilateral triangles formed by oriented parallelians, *Forum Geometricorum*, 1 (2001) 25 – 32.

## Chapter 9

# Circumconics

### 9.1 Circumconics as isogonal transforms of lines

A circumconic is one that passes through the vertices of the reference triangle. As such it is represented by an equation of the form

$$\mathcal{C} : \quad pyz + qzx + rxy = 0,$$

and can be regarded as the isogonal transform of the line

$$\mathcal{L} : \quad \frac{p}{a^2}x + \frac{q}{b^2}y + \frac{r}{c^2}z = 0.$$

The circumcircle is the isogonal transform of the line at infinity. Therefore, a circumconic is an ellipse, a parabola, or a hyperbola according as its isogonal transform intersects the circumcircle at 0, 1, or 2 real points.

Apart from the three vertices, the circumconic intersects the circumcircle at the isogonal conjugate of the infinite point of the line  $\mathcal{L}$ :

$$\left( \frac{1}{b^2r - c^2q} : \frac{1}{c^2p - a^2r} : \frac{1}{a^2q - b^2p} \right).$$

We call this the fourth intersection of the circumconic with the circumcircle.

#### Examples

(1) The Lemoine axis is the tripolar of the Lemoine (symmedian) point, the line with equation

$$\frac{x}{a^2} + \frac{y}{b^2} + \frac{z}{c^2} = 0.$$

Its isogonal transform is the Steiner circum-ellipse

$$yz + zx + xy = 0.$$

The fourth intersection with the circumcircle at the Steiner point <sup>1</sup>

$$\left( \frac{1}{b^2 - c^2} : \frac{1}{c^2 - a^2} : \frac{1}{a^2 - b^2} \right).$$

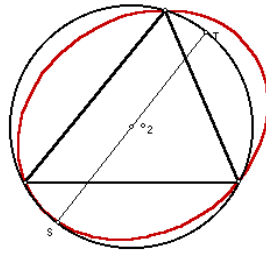

(1) The Euler line  $\sum_{\text{cyclic}}(b^2 - c^2)S_Ax = 0$  transforms into the *Jerabek hyperbola*

$$\sum_{\text{cyclic}} a^2(b^2 - c^2)S_Ayz = 0.$$

Since the Euler infinity point  $= (SS - 3S_{BC} : SS - 3S_{CA} : SS - 3S_{AB}) = (S_{CA} + S_{AB} - 2S_{BC} : \dots : \dots)$ , the fourth intersection with the circumcircle is the point <sup>2</sup>

$$\left( \frac{a^2}{S_{CA} + S_{AB} - 2S_{BC}} : \dots : \dots \right).$$

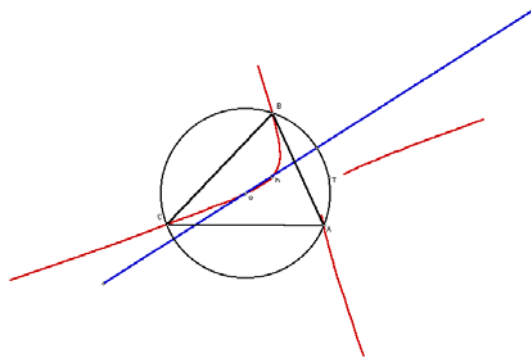

<sup>1</sup>The Steiner point appears as  $X_{99}$  in ETC.

<sup>2</sup>This is the point  $X_{74}$  in ETC.

(2) The Brocard axis  $OK$  has equation

$$b^2c^2(b^2 - c^2)x + c^2a^2(c^2 - a^2)y + a^2b^2(a^2 - b^2)z = 0.$$

Its isogonal transform is the *Kiepert hyperbola*

$$(b^2 - c^2)yz + (c^2 - a^2)zx + (a^2 - b^2)xy = 0.$$

The fourth intersection with the circumcircle is the *Tarry point* <sup>3</sup>

$$\left( \frac{1}{S_{BC} - S_{AA}} : \frac{1}{S_{CA} - S_{BB}} : \frac{1}{S_{AB} - S_{CC}} \right).$$

This is antipodal to the Steiner point, since the Eule line and the Lemoine axis are perpendicular to each other. <sup>4</sup>

(4) Recall that the tangent to the nine-point circle at the Feuerbach point  $F = ((b - c)^2(b + c - a) : (c - a)^2(c + a - b) : (a - b)^2(a + b - c))$  is the line

$$\frac{x}{b - c} + \frac{y}{c - a} + \frac{z}{a - b} = 0.$$

Applying the homothety  $h(G, -2)$ , we obtain the line

$$(b - c)^2x + (c - a)^2y + (a - b)^2z = 0$$

tangent to the point  $(\frac{a}{b-c} : \frac{b}{c-a} : \frac{c}{a-b})$  at the circumcircle. <sup>5</sup>

The isogonal transform of this line is the parabola

$$a^2(b - c)^2yz + b^2(c - a)^2zx + c^2(a - b)^2xy = 0.$$

## Exercises

1. Let  $P$  be a point. The first trisection point of the cevian  $AP$  is the point  $A'$  dividing  $AA_P$  in the ratio  $1 : 2$ , *i.e.*,  $AA' : A'A_P = 1 : 2$ . Find the locus of  $P$  for which the first trisection points of the three cevians are collinear. For each such  $P$ , the line containing the first trisection points always passes through the centroid.
2. Show that the Tarry point as a Kiepert perspector is  $K(-(\frac{\pi}{2} - \omega))$ .

<sup>3</sup>The Tarry point appears as the point  $X_{98}$  in ETC.

<sup>4</sup>The Lemoine axis is the radical axis of the circumcircle and the nine-point; it is perpendicular to the Euler line joining the centers of the two circles.

<sup>5</sup>This point appears as  $X_{100}$  in ETC.

3. Show that the circumconic  $pyz + qzx + rxy = 0$  is a parabola if and only if

$$p^2 + q^2 + r^2 - 2qr - 2rp - 2pq = 0.$$

4. **Animate** a point  $P$  on the circumcircle of triangle  $ABC$  and draw the line  $OP$ .
- Construct the point  $Q$  on the circumcircle which is the isogonal conjugate of the infinite point of  $OP$ .
  - Construct the tangent at  $Q$ .
  - Choose** a point  $X$  on the tangent line at  $Q$ , and construct the **isogonal conjugate**  $X^*$  of  $X$ .
  - Find the **locus** of  $X^*$ .

## 9.2 The infinite points of a circum-hyperbola

Consider a line  $\mathcal{L}$  intersecting the circumcircle at two points  $P$  and  $Q$ . The isogonal transform of  $\mathcal{L}$  is a circum-hyperbola  $\mathcal{C}$ . The directions of the asymptotes of the hyperbola are given by its two infinite points, which are the isogonal conjugates of  $P$  and  $Q$ . The angle between them is one half of that of the arc  $PQ$ .

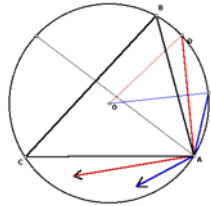

These asymptotes are perpendicular to each other if and only if  $P$  and  $Q$  are antipodal. In other words, the circum-hyperbola is rectangular, if and only if its isogonal transform is a diameter of the circumcircle. This is also equivalent to saying that the circum-hyperbola is rectangular if and only if it contains the orthocenter of triangle  $ABC$ .

### Theorem

Let  $P$  and  $Q$  be antipodal points on the circumcircle. The asymptotes of the rectangular circum-hyperbola which is the isogonal transform of  $PQ$  are the Simson lines of  $P$  and  $Q$ .

It follows that the center of the circum-hyperbola is the intersection of these Simson lines, and is a point on the nine-point circle.

### Exercises

1. Let  $P = (u : v : w)$  be a point other than the orthocenter and the vertices of triangle  $ABC$ . The rectangular circum-hyperbola through  $P$  has equation

$$\sum_{\text{cyclic}} u(S_B v - S_C w)yz = 0.$$

## 9.3 The perspector and center of a circumconic

The tangents at the vertices of the circumconic

$$pyz + qzx + rxy = 0$$

are the lines

$$ry + qz = 0, \quad rx + pz = 0, \quad qx + py = 0.$$

These bound the triangle with vertices

$$(-p : q : r), \quad (p : -q : r), \quad (p : q : -r).$$

This is perspective with  $ABC$  at the point  $P = (p : q : r)$ , which we shall call the perspector of the circumconic.

We shall show in a later section that the center of the circumconic is the cevian quotient

$$Q = G/P = (u(v + w - u) : v(w + u - v) : w(u + v - w)).$$

Here we consider some interesting examples based on the fact that  $P = G/Q$  if  $Q = G/P$ . This means that the circumconics with centers  $P$  and  $Q$  have perspectors at the other point. The two circumconics intersect at

$$\left( \frac{u}{v-w} : \frac{v}{w-u} : \frac{w}{u-v} \right).$$

### 9.3.1 Examples

#### Circumconic with center $K$

Since the circumcircle (with center  $O$ ) has perspector at the symmedian point  $K$ , the circumconic with center  $K$  has  $O$  as perspector. This intersects the circumcircle at the point <sup>6</sup>

$$\left( \frac{a^2}{b^2 - c^2} : \frac{b^2}{c^2 - a^2} : \frac{c^2}{a^2 - b^2} \right).$$

This point can be called the Euler infinity point.

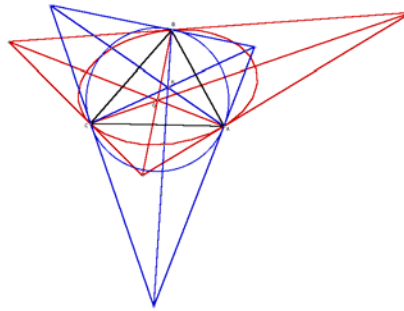

#### Circumconic with incenter as perspector

The circumconic with incenter as perspector has equation

$$ayz + bzx + cxy = 0.$$

This has center  $G/I = (a(b + c - a) : b(c + a - b) : c(a + b - c))$ , the Mittenpunkt. The circumconic with the incenter as center has equation

$$a(s - a)yz + b(s - b)zx + c(s - c)xy = 0.$$

The two intersect at the point <sup>7</sup>

$$\left( \frac{a}{b - c} : \frac{b}{c - a} : \frac{c}{a - b} \right)$$

which is a point on the circumcircle.

<sup>6</sup>This point appears as  $X_{110}$  in ETC.

<sup>7</sup>This point appears as  $X_{100}$  in ETC.

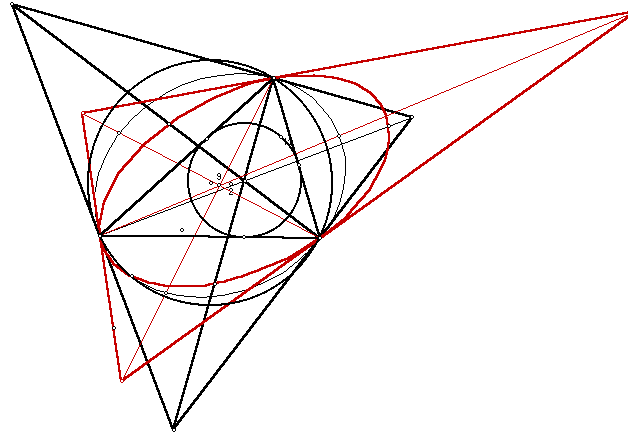

### Exercises

- Let  $P$  be the Spieker center, with coordinates  $(b + c : c + a : a + b)$ .
  - Show that the circumconic with perspector  $P$  is an ellipse.
  - Find the center  $Q$  of the conic.<sup>8</sup>
  - Show that the circumconic with center  $P$  (and perspector  $Q$ ) is also an ellipse.
  - Find the intersection of the two conics.<sup>9</sup>
- If  $P$  is the midpoint of the Brocard points  $\Omega_{\rightarrow}$  and  $\Omega_{\leftarrow}$ , what is the point  $Q = G/P$ ? What is the common point of the two circumconics with centers and perspectors at  $P$  and  $Q$ ?<sup>10</sup>
- Let  $P$  and  $Q$  be the center and perspector of the Kiepert hyperbola. Why is the circumconic with center  $Q$  and perspector  $P$  a parabola? What is the intersection of the two conics?<sup>11</sup>
- Animate a point  $P$  on the circumcircle and construct the **circumconic** with  $P$  as center. What can you say about the type of the conic as  $P$  varies on the circumcircle?

<sup>8</sup> $Q = (a(b + c) : b(c + a) : c(a + b))$ . This point appears in ETC as  $X_{37}$ .

<sup>9</sup> $(\frac{b-c}{b+c} : \frac{c-a}{c+a} : \frac{a-b}{a+b})$ . This point does not appear in the current edition of ETC.

<sup>10</sup> $Q =$  symmedian point of medial triangle; common point  $= (\frac{b^2-c^2}{b^2+c^2} : \dots : \dots)$ . This point does not appear in the current edition of ETC.

<sup>11</sup> $(\frac{b^2-c^2}{b^2+c^2-2a^2} : \dots : \dots)$ . This point does not appear in the current edition of ETC.



5. Animate a point  $P$  on the circumcircle and construct the **circumconic** with  $P$  as perspector. What can you say about the type of the conic as  $P$  varies on the circumcircle?

#### 9.4 Appendix: Ruler construction of tangent at $A$

- (1)  $P = AC \cap BD$ ;  
 (2)  $Q = AD \cap CE$ ;  
 (3)  $R = PQ \cap BE$ .  
 Then  $AR$  is the tangent at  $A$ .

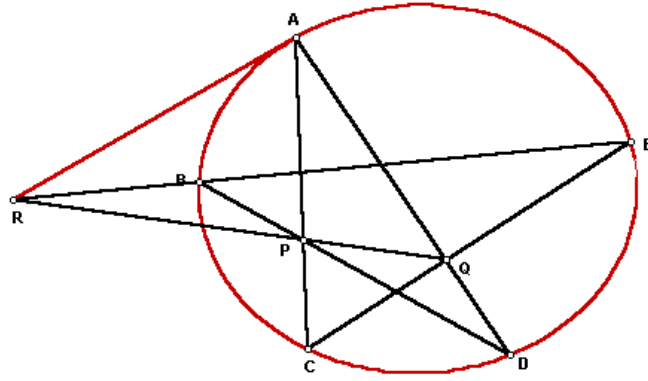

# Chapter 10

## General Conics

### 10.1 Equation of conics

#### 10.1.1 Carnot's Theorem

Suppose a conic  $\mathcal{C}$  intersect the side lines  $BC$  at  $X, X'$ ,  $CA$  at  $Y, Y'$ , and  $AB$  at  $Z, Z'$ , then

$$\frac{BX}{XC} \cdot \frac{BX'}{X'C} \cdot \frac{CY}{YA} \cdot \frac{CY'}{Y'A} \cdot \frac{AZ}{ZB} \cdot \frac{AZ'}{Z'B} = 1.$$

*Proof.* Write the equation of the conic as

$$fx^2 + gy^2 + hz^2 + 2pyz + 2qzx + 2rxy = 0.$$

The intersections with the line  $BC$  are the two points  $(0 : y_1 : z_1)$  and  $(0 : y_2 : z_2)$  satisfying

$$gy^2 + hz^2 + 2pyz = 0.$$

From this,

$$\frac{BX}{XC} \cdot \frac{BX'}{X'C} = \frac{z_1 z_2}{y_1 y_2} = \frac{g}{h}.$$

Similarly, for the other two pairs of intersections, we have

$$\frac{CY}{YA} \cdot \frac{CY'}{Y'A} = \frac{h}{f}, \quad \frac{AZ}{ZB} \cdot \frac{AZ'}{Z'B} = \frac{f}{g}.$$

The product of these division ratios is clearly 1.

The converse of Carnot's theorem is also true: if  $X, X', Y, Y', Z, Z'$  are points on the side lines such that

$$\frac{BX}{XC} \cdot \frac{BX'}{X'C} \cdot \frac{CY}{YA} \cdot \frac{CY'}{Y'A} \cdot \frac{AZ}{ZB} \cdot \frac{AZ'}{Z'B} = 1,$$

then the 6 points are on a conic.

**Corollary**

If  $X, Y, Z$  are the traces of a point  $P$ , then  $X', Y', Z'$  are the traces of another point  $Q$ .

**10.1.2 Conic through the traces of  $P$  and  $Q$** 

Let  $P = (u : v : w)$  and  $Q = (u' : v' : w')$ . By Carnot's theorem, there is a conic through the 6 points. The equation of the conic is

$$\sum_{\text{cyclic}} \frac{x^2}{uw'} - \left( \frac{1}{vw'} + \frac{1}{v'w} \right) yz = 0.$$

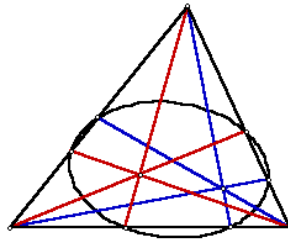
**Exercises**

1. Show that the points of tangency of the  $A$ -excircle with  $AB, AC$ , the  $B$ -excircle with  $BC, AB$ , and the  $C$ -excircle with  $CA, CB$  lie on a conic. Find the equation of the conic. <sup>1</sup>
2. Let  $P = (u : v : w)$  be a point not on the side lines of triangle  $ABC$ .
  - (a) Find the equation of the conic through the traces of  $P$  and the midpoints of the three sides. <sup>2</sup>
  - (b) Show that this conic passes through the midpoints of  $AP, BP$  and  $CP$ .
  - (c) For which points is the conic an ellipse, a hyperbola?

---

<sup>1</sup> $\sum_{\text{cyclic}} x^2 + \frac{s^2 + (s-a)^2}{s(s-a)} yz = 0.$   
<sup>2</sup> $\sum_{\text{cyclic}} -vwx^2 + u(v+w)yz = 0.$

3. Given two points  $P = (u : v : w)$  and a line  $\mathcal{L} : \frac{x}{u'} + \frac{y}{v'} + \frac{z}{w'} = 0$ , find the locus of the pole of  $\mathcal{L}$  with respect to the circumconics through  $P$ .

3

## 10.2 Inscribed conics

An *inscribed* conic is one tangent to the three side lines of triangle  $ABC$ . By Carnot's theorem, the points of tangency must either be the traces of a point  $P$  (Ceva Theorem) or the intercepts of a line (Menelaus Theorem). Indeed, if the conic is non-degenerate, the former is always the case. If the conic is tangent to  $BC$  at  $(0 : q : r)$  and to  $CA$  at  $(p : 0 : r)$ , then its equation must be

$$\frac{x^2}{p^2} + \frac{y^2}{q^2} + \frac{z^2}{r^2} - \frac{2yz}{qr} - \frac{2zx}{rp} - \epsilon \frac{2xy}{pq} = 0$$

for  $\epsilon = \pm 1$ . If  $\epsilon = -1$ , then the equation becomes

$$\left(-\frac{x}{p} + \frac{y}{q} + \frac{z}{r}\right)^2 = 0,$$

and the conic is degenerate. The inscribed conic therefore has equation

$$\frac{x^2}{p^2} + \frac{y^2}{q^2} + \frac{z^2}{r^2} - \frac{2yz}{qr} - \frac{2zx}{rp} - \frac{2xy}{pq} = 0$$

and touches  $BC$  at  $(0 : q : r)$ . The points of tangency form a triangle perspective with  $ABC$  at  $(p : q : r)$ , which we call the perspector of the inscribed conic.

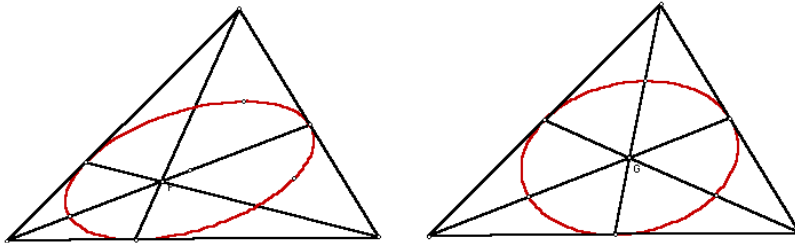

<sup>3</sup>The conic through the traces of  $P$  and  $Q = (u' : v' : w)$ ; Jean-Pierre Ehrmann, Hyacinthos, message 1326, 9/1/00.

### 10.2.1 The Steiner in-ellipse

The Steiner in-ellipse is the inscribed conic with perspector  $G$ . It has equation

$$x^2 + y^2 + z^2 - 2yz - 2zx - 2xy = 0.$$

#### Exercises

1. The locus of the squares of infinite points is the Steiner in-ellipse

$$x^2 + y^2 + z^2 - 2yz - 2zx - 2xy = 0.$$

2. Let  $\mathcal{C}$  be the inscribed conic

$$\sum_{\text{cyclic}} \frac{x^2}{p^2} - \frac{2yz}{qr} = 0,$$

tangent to the side lines at  $X = (0 : q : r)$ ,  $Y = (p : 0 : r)$ , and  $Z = (0 : p : q)$  respectively. Consider an arbitrary point  $Q = (u : v : w)$ .

- (a) Find the coordinates of the second intersection  $A'$  of  $\mathcal{C}$  with  $XQ$ .<sup>4</sup>
- (b) Similarly define  $B'$  and  $C'$ . Show that triangle  $A'B'C'$  is perspective with  $ABC$ , and find the perspector.<sup>5</sup>

### 10.3 The adjoint of a matrix

The *adjoint* of a matrix (not necessarily symmetric)

$$M = \begin{pmatrix} a_{11} & a_{12} & a_{13} \\ a_{21} & a_{22} & a_{23} \\ a_{31} & a_{32} & a_{33} \end{pmatrix}$$

is the *transpose* of the matrix formed by the cofactors of  $M$ :

$$M^\# = \begin{pmatrix} a_{22}a_{33} - a_{23}a_{32} & -a_{12}a_{33} + a_{13}a_{32} & a_{12}a_{23} - a_{22}a_{13} \\ -a_{21}a_{33} + a_{23}a_{31} & a_{11}a_{33} - a_{13}a_{31} & -a_{11}a_{23} + a_{21}a_{13} \\ a_{21}a_{32} - a_{31}a_{22} & -a_{11}a_{32} + a_{31}a_{12} & a_{11}a_{22} - a_{12}a_{21} \end{pmatrix}$$

<sup>4</sup> $(\frac{4u^2}{p} : q(\frac{u}{p} + \frac{v}{q} - \frac{w}{r})^2 : r(\frac{u}{p} - \frac{v}{q} + \frac{w}{r})^2)$ .

<sup>5</sup> $(\frac{p}{(-\frac{u}{p} + \frac{v}{q} + \frac{w}{r})^2} : \dots : \dots)$ .

**Proposition**

- (1)  $MM^\# = M^\#M = \det(M)I$ .  
 (2)  $M^{\#\#} = (\det M)M$ .

**Proposition**

Let  $(i, j, k)$  be a permutation of the indices 1, 2, 3.

- (1) If the rows of a matrix  $M$  are the coordinates of three points, the line joining  $P_i$  and  $P_k$  has coordinates given by the  $k$ -th column of  $M^\#$ .  
 (2) If the columns of a matrix  $M$  are the coordinates of three lines, the intersection of  $L_i$  and  $L_j$  is given by the  $k$ -row of  $M^\#$ .

**10.4 Conics parametrized by quadratic functions**

Suppose

$$x : y : z = a_0 + a_1t + a_2t^2 : b_0 + b_1t + b_2t^2 : c_0 + c_1t + c_2t^2$$

Elimination of  $t$  gives

$$(p_1x + q_1y + r_1z)^2 - (p_0x + q_0y + r_0z)(p_2x + q_2y + r_2z) = 0,$$

where the coefficients are given by the entries of the adjoint of the matrix

$$M = \begin{pmatrix} a_0 & a_1 & a_2 \\ b_0 & b_1 & b_2 \\ c_0 & c_1 & c_2 \end{pmatrix},$$

namely,

$$M^\# = \begin{pmatrix} p_0 & q_0 & r_0 \\ p_1 & q_1 & r_1 \\ p_2 & q_2 & r_2 \end{pmatrix}.$$

This conic is nondegenerate provided  $\det(M) \neq 0$ .

**10.4.1 Locus of Kiepert perspectors**

Recall that the apexes of similar isosceles triangles of base angles  $\theta$  constructed on the sides of triangle  $ABC$  form a triangle  $A^\theta B^\theta C^\theta$  with perspector

$$K(\theta) = \left( \frac{1}{S_A + S_\theta} : \frac{1}{S_B + S_\theta} : \frac{1}{S_C + S_\theta} \right).$$

Writing  $t = S_\theta$ , and clearing denominators, we may take

$$(x : y : z) = (S_{BC} + a^2t + t^2 : S_{CA} + b^2t + t^2 : S_{AB} + c^2t + t^2).$$

With

$$M = \begin{pmatrix} S_{BC} & a^2 & 1 \\ S_{CA} & b^2 & 1 \\ S_{AB} & c^2 & 1 \end{pmatrix},$$

we have

$$M^\# = \begin{pmatrix} b^2 - c^2 & c^2 - a^2 & a^2 - b^2 \\ -S_A(b^2 - c^2) & -S_B(c^2 - a^2) & -S_C(a^2 - b^2) \\ S_{AA}(b^2 - c^2) & S_{BB}(c^2 - a^2) & S_{CC}(a^2 - b^2) \end{pmatrix}$$

Writing  $u = (b^2 - c^2)x$ ,  $v = (c^2 - a^2)y$ , and  $w = (a^2 - b^2)z$ , we have

$$(S_Au + S_Bv + S_Cw)^2 - (u + v + w)(S_{AA}u + S_{BB}v + S_{CC}w) = 0,$$

which simplifies into

$$0 = \sum_{\text{cyclic}} (2S_{BC} - S_{BB} - S_{CC})vw = - \sum_{\text{cyclic}} (b^2 - c^2)^2vw.$$

In terms of  $x, y, z$ , we have, after deleting a common factor  $-(a^2 - b^2)(b^2 - c^2)(c^2 - a^2)$ ,

$$\sum_{\text{cyclic}} (b^2 - c^2)yz = 0.$$

This is the circum-hyperbola which is the isogonal transform of the line

$$\sum_{\text{cyclic}} b^2c^2(b^2 - c^2)x = 0.$$

## 10.5 The matrix of a conic

### 10.5.1 Line coordinates

In working with conics, we shall find it convenient to use matrix notations. We shall identify the homogeneous coordinates of a point  $P = (x : y : z)$  with the *row matrix*  $(x \ y \ z)$ , and denote it by the same  $P$ . A line  $\mathcal{L}$  with equation  $px + qy + rz = 0$  is represented by the *column matrix*

$$L = \begin{Bmatrix} p \\ q \\ r \end{Bmatrix}$$

(so that  $PL = 0$ ). We shall call  $L$  the *line coordinates* of  $\mathcal{L}$ .

### 10.5.2 The matrix of a conic

A conic given by a quadratic equation

$$fx^2 + gy^2 + hz^2 + 2pyz + 2qzx + 2rxy = 0$$

can be represented by in matrix form  $PMP^t = 0$ , with

$$M = \begin{pmatrix} f & r & q \\ r & g & p \\ q & p & h \end{pmatrix}.$$

We shall denote the conic by  $\mathcal{C}(M)$ .

### 10.5.3 Tangent at a point

Let  $P$  be a point on the conic  $\mathcal{C}$ . The *tangent* at  $P$  is the line  $MP^t$ .

## 10.6 The dual conic

### 10.6.1 Pole and polar

The *polar* of a point  $P$  (with respect to the conic  $\mathcal{C}(M)$ ) is the line  $MP^t$ , and the *pole* of a line  $L$  is the point  $L^tM^\#$ .

Conversely, if  $L$  intersects a conic  $\mathcal{C}$  at two points  $P$  and  $Q$ , the *pole* of  $L$  with respect to  $\mathcal{C}$  is the intersection of the tangents at  $P$  and  $Q$ .

### Exercises

1. A conic is self-polar if each vertex is the pole of its opposite side. Show that the matrix of a self-polar conic is a diagonal matrix.
2. If  $P$  lies on the polar of  $Q$ , then  $Q$  lies on the polar of  $P$ .

### 10.6.2 Condition for a line to be tangent to a conic

A line  $L : px + qy + rz = 0$  is tangent to the conic  $\mathcal{C}(M)$  if and only if  $L^tM^\#L = 0$ . If this condition is satisfied, the point of tangency is  $L^tM^\#$ .



### 10.6.3 The dual conic

Let  $M$  be the symmetric matrix

$$\begin{pmatrix} f & r & q \\ r & g & p \\ q & p & h \end{pmatrix}.$$

The *dual conic* of  $\mathcal{C} = \mathcal{C}(M)$  is the conic represented by the adjoint matrix

$$M^\# = \begin{pmatrix} gh - p^2 & pq - rh & rp - gq \\ pq - hr & hf - q^2 & qr - fp \\ rp - gq & qr - fp & fg - r^2 \end{pmatrix}.$$

Therefore, a line  $L : px + qy + rz = 0$  is tangent to  $\mathcal{C}(M)$  if and only if the point  $L^t = (p : q : r)$  is on the dual conic  $\mathcal{C}(M^\#)$ .

### 10.6.4 The dual conic of a circumconic

The dual conic of the circumconic  $pyz + qzx + rxy = 0$  (with perspector  $P = (p : q : r)$ ) is the inscribed conic

$$\sum_{\text{cyclic}} -p^2x^2 + 2qryz = 0$$

with perspector  $P^\bullet = (\frac{1}{p} : \frac{1}{q} : \frac{1}{r})$ . The center is the point  $(q+r : r+p : p+q)$ .

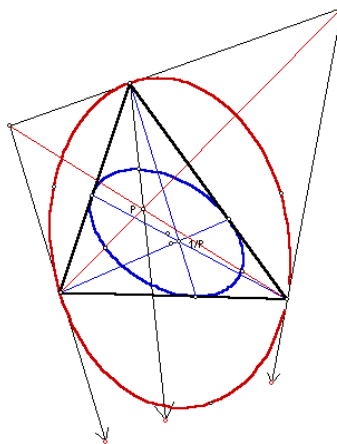

## Exercises

1. The polar of  $(u : v : w)$  with respect to the circumconic  $pyz + qzx + rxy = 0$  is the line

$$p(wy + vz) + q(uz + wx) + r(vx + uy) = 0.$$

2. Find the equation of the dual conic of the incircle. Deduce Feuerbach's theorem by showing that the radical axis of the nine-point circle and the incircle, namely, the line

$$\frac{x}{b-c} + \frac{y}{c-a} + \frac{z}{a-b} = 0$$

is tangent to the incircle.<sup>6</sup>

3. Show that the common tangent to the incircle and the nine-point circle is also tangent to the Steiner in-ellipse. Find the coordinates of the point of tangency.<sup>7</sup>
4. Let  $P = (u : v : w)$  and  $Q = (u' : v' : w')$  be two given points. If

$$X = B_P C_P \cap A A_Q, \quad Y = C_P A_P \cap B B_Q, \quad Z = A_P B_P \cap C C_Q,$$

show that  $A_P X$ ,  $B_P Y$  and  $C_P Z$  are concurrent at the pole of  $PQ$  with respect to the circumconic through  $P$  and  $Q$ .<sup>8</sup>

5. The tangents at the vertices to the circumcircle of triangle  $ABC$  intersect the side lines  $BC$ ,  $CA$ ,  $AB$  at  $A'$ ,  $B'$ ,  $C'$  respectively. The *second* tangents from  $A'$ ,  $B'$ ,  $C'$  to the circumcircle have points of tangency  $X$ ,  $Y$ ,  $Z$  respectively. Show that  $XYZ$  is perspective with  $ABC$  and find the perspector.<sup>9</sup>

---

<sup>6</sup> $\sum_{\text{cyclic}} (s-a)yz = 0$ .

<sup>7</sup> $((b-c)^2 : (c-a)^2 : (a-b)^2)$ . This point appears as  $X_{1086}$  in ETC.

<sup>8</sup>O. Bottema, Une construction par rapport à un triangle, *Nieuw Archief voor Wiskunde*, IV 5 (1957) 68–70.

<sup>9</sup> $(a^2(b^4+c^4-a^4) : \dots : \dots)$ . This is a point on the Euler line. It appears as  $X_{22}$  in ETC. See D.J. Smeenk and C.J. Bradley, Problem 2096 and solution, *Cruz Mathematicorum*, 21 (1995) 344; 22(1996) 374 – 375.

## 10.7 The type, center and perspector of a conic

### 10.7.1 The type of a conic

The conic  $\mathcal{C}(M)$  is an ellipse, a parabola, or a hyperbola according as the characteristic  $GM^\#G$  is positive, zero, or negative.

*Proof.* Setting  $z = -(x + y)$ , we reduce the equation of the conic into

$$(h + f - 2q)x^2 + 2(h - p - q + r)xy + (g + h - 2p)y^2 = 0.$$

This has discriminant

$$\begin{aligned} & (h - p - q + r)^2 - (g + h - 2p)(h + f - 2q) \\ = & h^2 - (g + h)(h + f) - 2h(p + q - r) \\ & + 2(h + f)p + 2(g + h)q + (p + q - r)^2 + 4pq \\ = & -(fg + gh + hf) + 2(fp + gq + hr) + (p^2 + q^2 + r^2 - 2pq - 2qr - 2rp) \end{aligned}$$

which is the negative of the sum of the entries of  $M^\#$ . From this the result follows.

### 10.7.2 The center of a conic

The center of a conic is the pole of the line at infinity. As such, the center of  $\mathcal{C}(M)$  has coordinates  $GM^\#$ , formed by the column sums of  $M^\#$ :

$$(p(q+r-p) - (qg+rh) + gh) : q(r+p-q) - (rh+pf) + hf : r(p+q-r) - (pf+qg) + fg).$$

### 10.7.3 The perspector of a conic

#### Theorem (Conway)

Let  $\mathcal{C} = \mathcal{C}(M)$  be a nondegenerate, non-self-polar conic. The triangle formed by the polars of the vertices is perspective with  $ABC$ , and has perspector  $(p : q : r)$ .

*Proof.* Since the polars are represented by the columns of  $M^\#$ , their intersections are represented by the rows of  $M^{\#\#} = (\det M)M$ . The result follows since  $\det M \neq 0$ .

The point  $(p : q : r)$  is called the *perspector* of the conic  $\mathcal{C}(M)$ .

**Proposition**

The center of the inscribed conic with perspector  $P$  is the inferior of  $P^\bullet$ .

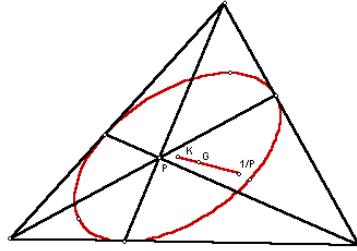

*Proof.* The inscribed conic with perspector  $P$  has equation

$$\sum_{\text{cyclic}} \frac{x^2}{p^2} - \frac{2yz}{qr} = 0.$$

**Exercises**

- Let  $(f : g : h)$  be an infinite point. What type of conic does the equation

$$\frac{a^2x^2}{f} + \frac{b^2y^2}{g} + \frac{c^2z^2}{h} = 0$$

represent? <sup>10</sup>

- Find the perspector of the conic through the traces of  $P$  and  $Q$ .
- Find the perspector of the conic through the 6 points of tangency of the excircles with the side lines. <sup>11</sup>
- A circumconic is an ellipse, a parabola or a hyperbola according as the perspector is inside, on, or outside the Steiner in-ellipse.
- Let  $\mathcal{C}$  be a conic tangent to the side lines  $AB$  and  $AC$  at  $B$  and  $C$  respectively.
  - Show that the equation of  $\mathcal{C}$  is of the form  $x^2 - kyz = 0$  for some  $k$ .
  - Show that the center of the conic lies on the  $A$ -median.
  - Construct the parabola in this family as a five-point conic. <sup>12</sup>

<sup>10</sup>Parabola.

<sup>11</sup> $(\frac{a^2+(b+c)^2}{b+c-a} : \dots : \dots)$ . This point appears in ETC as  $X_{388}$ .

<sup>12</sup>The parabola has equation  $x^2 - 4yz = 0$ .

- (d) Design an animation of the conic as its center traverses the  $A$ -median.<sup>13</sup>
6. Prove that the locus of the centers of circumconics through  $P$  is the conic through the traces of  $P$  and the midpoints of the sides.<sup>14</sup>

---

<sup>13</sup>If the center is  $(t : 1 : 1)$ , then the conic contains  $(t : -2 : t)$ .

<sup>14</sup>Floor van Lamoen and Paul Yiu, Conics loci associated with conics, *Forum Geometricorum*, forthcoming.

# Chapter 11

## Some Special Conics

### 11.1 Inscribed conic with prescribed foci

#### 11.1.1 Theorem

The foci of an inscribed central conic are isogonal conjugates.

*Proof.* Let  $F_1$  and  $F_2$  be the foci of a conic, and  $T_1, T_2$  the points of tangency from a point  $P$ . Then  $\angle F_1PT_1 = \angle F_2PT_2$ . Indeed, if  $Q_1, Q_2$  are the pedals of  $F_1, F_2$  on the tangents, the product of the distances  $F_1Q_1$  and  $F_2Q_2$  to the tangents is constant, being the square of the semi-minor axis.

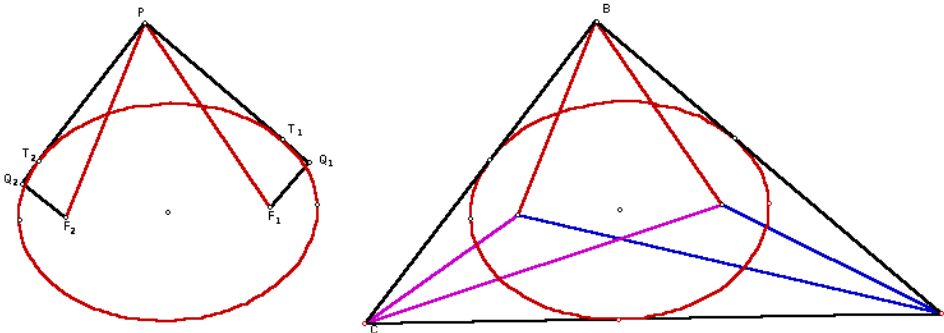

Given a pair of isogonal conjugates, there is an inscribed conic with foci at the two points. The center of the conic is the midpoint of the segment.

#### 11.1.2 The Brocard ellipse

$$\sum_{\text{cyclic}} b^4 c^4 x^2 - 2a^4 b^2 c^2 yz = 0$$

The Brocard ellipse is the inscribed ellipse with the Brocard points

$$\begin{aligned}\Omega_{\rightarrow} &= (a^2b^2 : b^2c^2 : c^2a^2), \\ \Omega_{\leftarrow} &= (c^2a^2 : a^2b^2 : b^2c^2).\end{aligned}$$

Its center is the Brocard midpoint

$$(a^2(b^2 + c^2) : b^2(c^2 + a^2) : c^2(a^2 + b^2)),$$

which is the inferior of  $(b^2c^2 : c^2a^2 : a^2b^2)$ , the isotomic conjugate of the symmedian point. It follows that the perspector is the symmedian point.

### Exercises

1. Show that the equation of the Brocard ellipse is as given above.
2. The minor auxiliary circle is tangent to the nine-point circle.<sup>1</sup> What is the point of tangency?<sup>2</sup>

### 11.1.3 The de Longchamps ellipse<sup>3</sup>

$$\sum_{\text{cyclic}} b^2c^2(b+c-a)x^2 - 2a^3bcyz = 0,$$

The de Longchamps ellipse is the conic through the traces of the incenter  $I$ , and has center at  $I$ .

### Exercises

1. Given that the equation of the conic is show that it is always an ellipse.
2. By Carnot's theorem, the "second" intersections of the ellipse with the side lines are the traces of a point  $P$ . What is this point?<sup>4</sup>
3. The minor axis of the ellipse is along the line  $OI$ . What are the lengths of the semi-major and semi-minor axes of the ellipse?<sup>5</sup>

<sup>1</sup>V. Thébault, Problem 3857, *American Mathematical Monthly*, APH,205.

<sup>2</sup>Jean-Pierre Ehrmann, Hyacinthos, message 209, 1/22/00.

<sup>3</sup>E. Catalan, Note sur l'ellipse de Longchamps, *Journal Math. Spéciales*, IV 2 (1893) 28-30.

<sup>4</sup> $(\frac{a}{s-a} : \frac{b}{s-b} : \frac{c}{s-c})$ .

<sup>5</sup> $\frac{R}{2}$  and  $r$

### 11.1.4 The Lemoine ellipse

Construct the inscribed conic with foci  $G$  and  $K$ .

Find the coordinates of the center and the perspector.

The points of tangency with the side lines are the traces of the  $G$ -symmedians of triangles  $GBC$ ,  $GCA$ , and  $GAB$ .

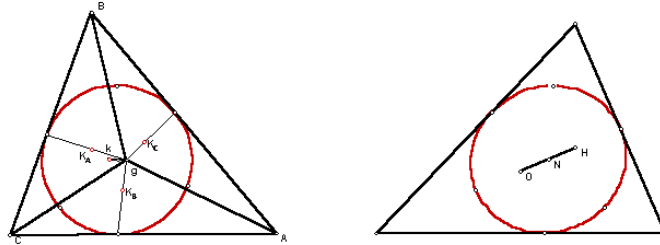

### 11.1.5 The inscribed conic with center $N$

This has foci  $O$  and  $H$ . The perspector is the isotomic conjugate of the circumcenter. It is the envelope of the perpendicular bisectors of the segments joining  $H$  to a point on the circumcircle. The major auxiliary circle is the nine-point circle.

#### Exercises

1. Show that the equation of the Lemoine ellipse is

$$\sum_{\text{cyclic}} m_a^4 x^2 - 2m_b^2 m_c^2 yz = 0$$

where  $m_a$ ,  $m_b$ ,  $m_c$  are the lengths of the medians of triangle  $ABC$ .

## 11.2 Inscribed parabola

Consider the inscribed parabola tangent to a given line, which we regard as the tripolar of a point  $P = (u : v : w)$ . Thus,  $\ell : \frac{x}{u} + \frac{y}{v} + \frac{z}{w} = 0$ . The dual conic is the circumconic passes through the centroid  $(1 : 1 : 1)$  and  $P^\bullet = (\frac{1}{u} : \frac{1}{v} : \frac{1}{w})$ . It is the circumconic

$$\mathcal{C}^\# \quad \frac{v-w}{x} + \frac{w-u}{y} + \frac{u-v}{z} = 0.$$



The inscribed parabola, being the dual of  $\mathcal{C}^\#$ , is

$$\sum_{\text{cyclic}} -(v-w)^2 x^2 + 2(w-u)(u-v)yz = 0.$$

The perspector is the isotomic conjugate of that of its dual. This is the point

$$\left( \frac{1}{v-w} : \frac{1}{w-u} : \frac{1}{u-v} \right)$$

on the Steiner circum-ellipse.

The center of the parabola is the infinite point  $(v-w : w-u : u-v)$ . This gives the direction of the axis of the parabola. It can also be regarded the infinite focus of the parabola. The other focus is the isogonal conjugate

$$\frac{a^2}{v-w} : \frac{b^2}{w-u} : \frac{c^2}{u-v}$$

on the circumcircle.

The axis is the line through this point parallel to  $ux + vy + wz = 0$ . The intersection of the axis with the parabola is the vertex

$$\left( \frac{(S_B(w-u) - S_C(u-v))^2}{v-w} : \dots : \dots \right).$$

The directrix, being the polar of the focus, is the line

$$S_A(v-w)x + S_B(w-u)y + S_C(u-v)z = 0.$$

This passes through the orthocenter, and is perpendicular to the line

$$ux + vy + wz = 0.$$

It is in fact the line of reflections of the focus. The tangent at the vertex is the Simson line of the focus.

Where does the parabola touch the given line?

$$(u^2(v-w) : v^2(w-u) : w^2(u-v)),$$

the barycentric product of  $P$  and the infinite point of its tripolar, the given tangent, or equivalently the barycentric product of the infinite point of the tangent and its tripole.

**Exercises**

1. Animate a point  $P$  on the Steiner circum-ellipse and construct the inscribed parabola with perspector  $P$ .

**11.3 Some special conics****11.3.1 The Steiner circum-ellipse  $xy + yz + zx = 0$** 

Construct the Steiner circum-ellipse which has center at the centroid  $G$ .

The fourth intersection with the circumcircle is the Steiner point, which has coordinates

$$\left( \frac{1}{b^2 - c^2} : \frac{1}{c^2 - a^2} : \frac{1}{a^2 - b^2} \right).$$

Construct this point as the isotomic conjugate of an infinite point.

The axes of the ellipse are the bisectors of the angle  $KGS$ .<sup>6</sup> Construct these axes, and the vertices of the ellipse.

Construct the foci of the ellipse.<sup>7</sup>

These foci are called the Bickart points. Each of them has the property that three cevian segments are equal in length.<sup>8</sup>

**11.3.2 The Steiner in-ellipse  $\sum_{\text{cyclic}} x^2 - 2yz = 0$** **Exercises**

1. Let  $\mathcal{C}$  be a circumconic through the centroid  $G$ . The tangents at  $A$ ,  $B$ ,  $C$  intersect the sidelines  $BC$ ,  $CA$ ,  $AB$  at  $A'$ ,  $B'$ ,  $C'$  respectively. Show that the line  $A'B'C'$  is tangent to the Steiner in-ellipse at the center of  $\mathcal{C}$ .<sup>9</sup>

---

<sup>6</sup>J.H. Conway, Hyacinthos, message 1237, 8/18/00.

<sup>7</sup>The principal axis of the Steiner circum-ellipse containing the foci is the *least square line* for the three vertices of the triangle. See F. Gremmen, Hyacinthos, message 260, 2/1/00.

<sup>8</sup>O. Bottema, On some remarkable points of a triangle, *Nieuw Archief voor Wiskunde*, 19 (1971) 46 – 57; J.R. Pounder, Equal cevians, *Cruz Mathematicorum*, 6 (1980) 98 – 104; postscript, *ibid.* 239 – 240.

<sup>9</sup>J.H. Tummers, Problem 32, *Wiskundige Oplossen met de Oplossingen*, 20-1 (1955) 31–32.

### 11.3.3 The Kiepert hyperbola $\sum_{\text{cyclic}}(b^2 - c^2)yz = 0$

The asymptotes are the Simson lines of the intersections of the Brocard axis  $OK$  with the circumcircle.<sup>10</sup> These intersect at the center which is on the nine-point circle. An easy way to construct the center as the intersection of the nine-point circle with the pedal circle of the centroid, *nearer to the orthocenter*.<sup>11</sup>

#### Exercises

1. Find the fourth intersection of the Kiepert hyperbola with the circumcircle, and show that it is antipodal to the Steiner point.<sup>12</sup>
2. Show that the Kiepert hyperbola is the locus of points whose tripolars are perpendicular to the Euler line.<sup>13</sup>
3. Let  $A'B'C'$  be the orthic triangle. The Brocard axes (the line joining the circumcenter and the symmedian point) of the triangles  $AB'C'$ ,  $A'BC'$ , and  $A'B'C$  intersect at the Kiepert center.<sup>14</sup>

### 11.3.4 The superior Kiepert hyperbola $\sum_{\text{cyclic}}(b^2 - c^2)x^2 = 0$

Consider the locus of points  $P$  for which the three points  $P$ ,  $P^\bullet$  (isotomic conjugate) and  $P^*$  (isogonal conjugate) are collinear. If  $P = (x : y : z)$ , then we require

$$\begin{aligned} 0 &= \begin{vmatrix} x & y & z \\ yz & zx & xy \\ a^2yz & b^2zx & c^2xy \end{vmatrix} \\ &= a^2xyz(y^2 - z^2) + b^2zxy(z^2 - x^2) + c^2xyz(x^2 - y^2) \\ &= -xyz((b^2 - c^2)x^2 + (c^2 - a^2)y^2 + (a^2 - b^2)z^2). \end{aligned}$$

<sup>10</sup>These asymptotes are also parallel to the axes of the Steiner ellipses. See, J.H. Conway, Hyacinthos, message 1237, 8/18/00.

<sup>11</sup>The other intersection is the center of the Jerabek hyperbola. This is based on the following theorem: Let  $P$  be a point on a rectangular circum-hyperbola  $\mathcal{C}$ . The pedal circle of  $P$  intersects the nine-point circle at the centers of  $\mathcal{C}$  and of (the rectangular circum-hyperbola which is) the isogonal conjugate of the line  $OP$ . See A.P. Hatzipolakis and P. Yiu, Hyacinthos, messages 1243 and 1249, 8/19/00.

<sup>12</sup>The Tarry point.

<sup>13</sup>O. Bottema and M.C. van Hoorn, Problem 664, *Nieuw Archief voor Wiskunde*, IV 1 (1983) 79. See also R.H. Eddy and R. Fritsch, On a problem of Bottema and van Hoorn, *ibid.*, IV 13 (1995) 165 – 172.

<sup>14</sup>Floor van Lamoen, Hyacinthos, message 1251, 8/19/00.

Excluding points on the side lines, the locus of  $P$  is the conic

$$(b^2 - c^2)x^2 + (c^2 - a^2)y^2 + (a^2 - b^2)z^2 = 0.$$

We note some interesting properties of this conic:

- It passes through the centroid and the vertices of the superior triangle, namely, the four points  $(\pm 1 : \pm 1 : \pm 1)$ .
- It passes through the four incenters, namely, the four points  $(\pm a : \pm b : \pm c)$ . Since these four points form an orthocentric quadruple, the conic is a rectangular hyperbola.
- Since the matrix representing the conic is diagonal, the center of the conic has coordinates  $(\frac{1}{b^2 - c^2} : \frac{1}{c^2 - a^2} : \frac{1}{a^2 - b^2})$ , which is the Steiner point.

### Exercises

1. All conics passing through the four incenters are tangent to four fixed straight lines. What are these lines? <sup>15</sup>
2. Let  $P$  be a given point other than the incenters. Show that the center of the conic through  $P$  and the four incenters is the fourth intersection of the circumcircle and the circumconic with perspector  $P \cdot P$  (barycentric square of  $P$ ). <sup>16</sup>
3. Let  $X$  be the pedal of  $A$  on the side  $BC$  of triangle  $ABC$ . For a real number  $t$ , let  $A_t$  be the point on the altitude through  $A$  such that  $XA_t = t \cdot XA$ . Complete the squares  $A_t X X_b A_b$  and  $A_t X X_c A_c$  with  $X_b$  and  $X_c$  on the line  $BC$ . <sup>17</sup> Let  $A'_t = BA_c \cap CA_b$ , and  $A''_t$  be the pedal of  $A'_t$  on the side  $BC$ . Similarly define  $B''_t$  and  $C''_t$ . Show that as  $t$  varies, triangle  $A''_t B''_t C''_t$  is perspective with  $ABC$ , and the perspector traverses the Kiepert hyperbola. <sup>18</sup>

### 11.3.5 The Feuerbach hyperbola

$$\sum_{\text{cyclic}} a(b - c)(s - a)yz = 0$$

<sup>15</sup>The conic  $\mathcal{C}$  is self-polar. Its dual conic passes through the four incenters. This means that the conic  $\mathcal{C}$  are tangent to the 4 lines  $\pm ax + \pm by + \pm cz = 0$ .

<sup>16</sup>Floor van Lamoen, Hyacinthos, message 1401, 9/11/00.

<sup>17</sup>A.P. Hatzipolakis, Hyacinthos, message 3370, 8/7/01.

<sup>18</sup>A.P. Hatzipolakis, Hyacinthos, message 3370, 8/7/01.

This is the isogonal transform of the  $OI$ -line. The rectangular hyperbola through the incenter. Its center is the Feuerbach point.

### 11.3.6 The Jerabek hyperbola

The Jerabek hyperbola

$$\sum_{\text{cyclic}} \frac{a^2(b^2 - c^2)S_A}{x} = 0$$

is the isogonal transform of the Euler line. Its center is the point

$$((b^2 - c^2)^2 S_A : (c^2 - a^2)^2 S_B : (a^2 - b^2)^2 S_C)$$

on the nine-point circle.<sup>19</sup>

#### Exercises

1. Find the coordinates of the fourth intersection of the Feuerbach hyperbola with the circumcircle.<sup>20</sup>
2. Animate a point  $P$  on the Feuerbach hyperbola, and construct its pedal circle. This pedal circle always passes through the Feuerbach point.
3. Three particles are moving at equal speeds along the perpendiculars from  $I$  to the side lines. They form a triangle perspective with  $ABC$ . The locus of the perspector is the Feuerbach hyperbola.
4. The Feuerbach hyperbola is the locus of point  $P$  for which the cevian quotient  $I/P$  lies on the  $OI$ -line.<sup>21</sup>
5. Find the fourth intersection of the Jerabek hyperbola with the circumcircle.<sup>22</sup>
6. Let  $\ell$  be a line through  $O$ . The tangent at  $H$  to the rectangular hyperbola which is the isogonal conjugate of  $\ell$  intersects  $\ell$  at a point on the Jerabek hyperbola.<sup>23</sup>

<sup>19</sup>The Jerabek center appears as  $X_{125}$  in ETC.

<sup>20</sup> $(\frac{a}{a^2(b+c)-2abc-(b+c)(b-c)^2} : \dots : \dots)$ . This point appears as  $X_{104}$  in ETC.

<sup>21</sup>P. Yiu, Hyacinthos, message 1013, 6/13/00.

<sup>22</sup> $(\frac{a^2}{2a^4 - a^2(b^2 + c^2) - (b^2 - c^2)^2} : \dots : \dots)$ . This point appears as  $X_{74}$  in ETC.

<sup>23</sup>B. Gibert, Hyacinthos, message 4247, 10/30/01.

## 11.4 Envelopes

The envelope of the parametrized family of lines

$$(a_0 + a_1t + a_2t^2)x + (b_0 + b_1t + b_2t^2)y + (c_0 + c_1t + c_2t^2)z = 0$$

is the conic<sup>24</sup>

$$(a_1x + b_1y + c_1z)^2 - 4(a_0x + b_0y + c_0z)(a_2x + b_2y + c_2z) = 0,$$

provided that the determinant

$$\begin{vmatrix} a_1 & a_1 & a_2 \\ b_0 & b_1 & b_2 \\ c_0 & c_1 & c_2 \end{vmatrix} \neq 0.$$

*Proof.* This is the dual conic of the conic parametrized by

$$x : y : z = a_0 + a_1t + a_2t^2 : b_0 + b_1t + b_2t^2 : c_0 + c_1t + c_2t^2.$$

### 11.4.1 The Artzt parabolas

Consider similar isosceles triangles  $A^\theta BC$ ,  $AB^\theta C$  and  $ABC^\theta$  constructed on the sides of triangle  $ABC$ . The equation of the line  $B^\theta C^\theta$  is

$$(S^2 - 2S_A t - t^2)x + (S^2 + 2(S_A + S_B)t + t^2)y + (S^2 + 2(S_C + S_A)t + t^2)z = 0,$$

where  $t = S_\theta = S \cdot \cot \theta$ . As  $\theta$  varies, this envelopes the conic

$$(-S_A x + c^2 y + b^2 z)^2 - S^2(x + y + z)(-x + y + z) = 0$$

### 11.4.2 Envelope of area-bisecting lines

Let  $Y$  be a point on the line  $AC$ . There is a unique point  $Z$  on  $AB$  such that the signed area of  $AZY$  is half of triangle  $ABC$ . We call  $YZ$  an area-bisecting line. If  $Y = (1 - t : 0 : t)$ , then  $Z = (1 - \frac{1}{2t} : \frac{1}{2t} : 0) = (2t - 1 : 1 : 0)$ . The line  $YZ$  has equation

$$0 = \begin{vmatrix} 1 - t & 0 & t \\ 2t - 1 & 1 & 0 \\ x & y & z \end{vmatrix} = -tx + (-t + 2t^2)y + (1 - t)z.$$

<sup>24</sup>This can be rewritten as  $\sum(4a_0a_2 - a_1^2)x^2 + 2(2(b_0c_2 + b_2c_0) - b_1c_1)yz = 0$ .

This envelopes the conic

$$(x + y + z)^2 - 8yz = 0.$$

This conic has representing matrix

$$M = \begin{pmatrix} 1 & 1 & 1 \\ 1 & 1 & -3 \\ 1 & -3 & 1 \end{pmatrix}$$

with adjoint matrix

$$M^\# = -4 \begin{pmatrix} 2 & 1 & 1 \\ 1 & 0 & -1 \\ 1 & -1 & 0 \end{pmatrix}.$$

This is a *hyperbola* with center at the vertex  $A$ .

To construct this as a 5-point conic, we need only find 3 points on the hyperbola. Here are three obvious points: the centroid  $G$ ,  $(1 : -1 : 0)$  and  $(1 : 0 : -1)$ . Unfortunately the latter two are infinite point: they give the lines  $AB$  and  $AC$  as asymptotes of the hyperbola. This means that the axes of the hyperbola are the bisectors of angle  $A$ . Thus images of  $G$  in these axes give three more points on the hyperbola. To find a fifth point, we set  $x = 0$  and obtain  $(y + z)^2 - 8yz = 0, \dots, y - 3z : z = \pm 2\sqrt{2} : 1$ ,

$$y : z = 3 \pm 2\sqrt{2} : 1 = (\sqrt{2} \pm 1)^2 : 1 = \sqrt{2} \pm 1 : \sqrt{2} \mp 1.$$

### 11.4.3 Envelope of perimeter-bisecting lines

Let  $Y$  be a point on the line  $AC$ . There is a unique point  $Z$  on  $AB$  such that the (signed) lengths of the segments  $AY$  and  $AZ$  add up to the semiperimeter of triangle  $ABC$ . We call  $YZ$  a perimeter-bisecting line. If  $AY = t$ , then  $AZ = s - t$ . The coordinates of the points are  $Y = (b - t : 0 : t)$  and  $Z = (c - s + t : s - t : 0)$ . The line  $YZ$  has equation

$$(t^2 - st)x + (t^2 - (s - c)t)y + (t^2 - (s + b)t + bs)z = 0.$$

These lines envelopes the conic

$$(sx + (s - c)y + (s + b)z)^2 - 4bsz(x + y + z) = 0$$

with representing matrix

$$\begin{pmatrix} s^2 & s(s - c) & s(s - b) \\ s(s - c) & (s - c)^2 & (s - b)(s - c) \\ s(s - b) & (s - b)(s - c) & (s - b)^2 \end{pmatrix}$$

with adjoint matrix

$$M^\# = -8bcs \begin{pmatrix} 2(s-a) & s-b & s-c \\ s-b & 0 & -s \\ s-c & -s & 0 \end{pmatrix}.$$

This conic is a parabola tangent to the lines  $CA$  and  $AB$  at the points  $(-(s-b) : 0 : s)$  and  $(-(s-c) : s : 0)$ .<sup>25</sup>

#### 11.4.4 The tripolars of points on the Euler line

A typical point on the Euler line

$$\sum_{\text{cyclic}} S_A(S_B - S_C)x = 0$$

has coordinates  $(S_{BC} + t : S_{CA} + t : S_{AB} + t)$ , with tripolar

$$\sum_{\text{cyclic}} \frac{1}{S_{BC} + t}x = 0,$$

or

$$0 = \sum_{\text{cyclic}} (v+t)(w+t)x = \sum_{\text{cyclic}} (S_{BC} + a^2 S_A t + t^2)x.$$

The envelope is the conic

$$(a^2 S_A x + b^2 S_B y + c^2 S_C z)^2 - 4S_{ABC}(x+y+z)(S_A x + S_B y + S_C z) = 0.$$

This can be rewritten as

$$\sum_{\text{cyclic}} S_{AA}(S_B - S_C)^2 x^2 - 2S_{BC}(S_C - S_A)(S_A - S_B)yz = 0.$$

This can be rewritten as

$$\sum_{\text{cyclic}} S_{AA}(S_B - S_C)^2 x^2 - 2S_{BC}(S_C - S_A)(S_A - S_B)yz = 0.$$

It is represented by the matrix

$$M = \begin{pmatrix} S_{AA}(S_B - S_C)^2 & -S_{AB}(S_B - S_C)(S_C - S_A) & -S_{CA}(S_A - S_B)(S_B - S_C) \\ -S_{AB}(S_B - S_C)(S_C - S_A) & S_{BB}(S_C - S_A) & -S_{BC}(S_C - S_A)(S_A - S_B) \\ S_{CA}(S_A - S_B)(S_B - S_C) & -S_{BC}(S_C - S_A)(S_A - S_B) & S_{CC}(S_A - S_B) \end{pmatrix}.$$

<sup>25</sup>These are the points of tangency of the  $A$ -excircle with the side lines.



This is clearly an inscribed conic, tangent to the side lines at the points  $(0 : S_C(S_A - S_B) : S_B(S_C - S_A))$ ,  $(S_C(S_A - S_B) : 0 : S_A(S_B - S_C))$ , and  $(S_B(S_C - S_A) : S_A(S_B - S_C) : 0)$ . The perspector is the point <sup>26</sup>

$$\left( \frac{1}{S_A(S_B - S_C)} : \frac{1}{S_B(S_C - S_A)} : \frac{1}{S_C(S_A - S_B)} \right).$$

The isotomic conjugate of this perspector being an infinite point, the conic is a parabola. <sup>27</sup>

### Exercises

1. **Animate** a point  $P$  on the circumcircle, and construct a circle  $\mathcal{C}(P)$ , center  $P$ , and radius half of the inradius. Find the envelope of the radical axis of  $\mathcal{C}(P)$  and the incircle.
2. **Animate** a point  $P$  on the circumcircle. Construct the isotomic conjugate of its isogonal conjugate, *i.e.*, the point  $Q = (P^*)^\bullet$ . What is the envelope of the line joining  $PQ$ ? <sup>28</sup>

---

<sup>26</sup>This point appears as  $X_{648}$  in ETC.

<sup>27</sup>The focus is the point  $X_{112}$  in ETC:

$$\left( \frac{a^2}{S_A(S_B - S_C)} : \frac{b^2}{S_B(S_C - S_A)} : \frac{c^2}{S_C(S_A - S_B)} \right).$$

Its directrix is the line of reflection of the focus, *i.e.*,

$$\sum_{\text{cyclic}} S_{AA}(S_B - S_C)x = 0.$$

<sup>28</sup>The Steiner point.

# Chapter 12

## Some More Conics

### 12.1 Conics associated with parallel intercepts

#### 12.1.1 Lemoine's theorem

Let  $P = (u : v : w)$  be a given point. Construct parallels through  $P$  to the side lines, intersecting the side lines at the points

$$\begin{aligned} Y_a &= (u : 0 : v + w), & Z_a &= (u : v + w : 0); \\ Z_b &= (w + u : v : 0), & X_b &= (0 : v : w + u); \\ X_c &= (0 : u + v : w), & Y_c &= (u + v : 0 : w). \end{aligned}$$

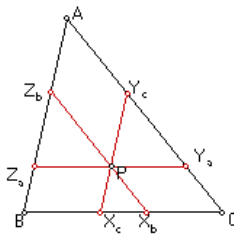

These 6 points lie on a conic  $\mathcal{C}_P$ , with equation

$$\sum_{\text{cyclic}} vw(v+w)x^2 - u(vw + (w+u)(u+v))yz = 0.$$

This equation can be rewritten as

$$\begin{aligned} & - (u+v+w)^2(uyz + vzx + wxy) \\ & + (x+y+z)(vw(v+w)x + wu(w+u)y + uv(u+v)z) = 0. \end{aligned}$$

From this we obtain

**Theorem (Lemoine)**

The conic through the 6 parallel intercepts of  $P$  is a circle if and only if  $P$  is the symmedian point.

**Exercises**

1. Show that the conic  $\mathcal{C}_P$  through the 6 parallel intercepts through  $P$  is an ellipse, a parabola, or a hyperbola according as  $P$  is inside, on, or outside the Steiner in-ellipse, and that its center is the midpoint of the  $P$  and the cevian quotient  $G/P$ .<sup>1</sup>
2. Show that the Lemoine circle is concentric with the Brocard circle.<sup>2</sup>

**12.1.2 A conic inscribed in the hexagon  $W(P)$** 

While  $\mathcal{C}_P$  is a conic circumscribing the hexagon  $W(P) = Y_a Y_c Z_b Z_a X_c X_b$ , there is another conic inscribed in the same hexagon. The sides of the hexagon have equations

$$\begin{aligned} Y_a Y_c : y &= 0; & Y_c Z_b : -vwx + w(w+u)y + v(u+v)z &= 0; \\ Z_b Z_a : z &= 0; & Z_a X_c : w(v+w)x - wuy + u(u+v)z &= 0; \\ X_c X_b : x &= 0; & X_b Y_a : v(v+w)x + u(w+u)y - uvz &= 0. \end{aligned}$$

These correspond to the following points on the dual conic: the vertices and

$$\left(-1 : \frac{w+u}{v} : \frac{u+v}{w}\right), \quad \left(\frac{v+w}{u} : -1 : \frac{u+v}{w}\right), \quad \left(\frac{v+w}{u} : \frac{w+u}{v} : -1\right).$$

It is easy to note that these six points lie on the circumconic

$$\frac{v+w}{x} + \frac{w+u}{y} + \frac{u+v}{z} = 0.$$

It follows that the 6 lines are tangent to the inscribed conic

$$\sum_{\text{cyclic}} (v+w)^2 x^2 - 2(w+u)(u+v)yz = 0,$$

with center  $(2u+v+w : u+2v+w : u+v+2w)$  and perspector

$$\left(\frac{1}{v+w} : \frac{1}{w+u} : \frac{1}{u+v}\right).$$

<sup>1</sup>The center has coordinates  $(u(2vw+u(v+w-u)) : v(2wu+v(w+u-v)) : w(2uv+w(u+v-w)))$ .

<sup>2</sup>The center of the Lemoine circle is the midpoint between  $K$  and  $G/K = O$ .

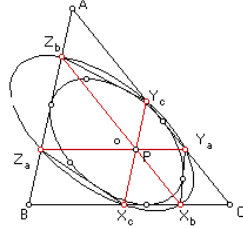

### Exercises

1. Find the coordinates of the points of tangency of this inscribed conic with the  $Y_cZ_b$ ,  $Z_aX_c$  and  $X_bY_a$ , and show that they form a triangle perspective with  $ABC$  at <sup>3</sup>

$$\left( \frac{u^2}{v+w} : \frac{v^2}{w+u} : \frac{w^2}{u+v} \right).$$

### 12.1.3 Centers of inscribed rectangles

Let  $P = (x : y : z)$  be a given point. Construct the inscribed rectangle whose top edge is the parallel to  $BC$  through  $P$ . The vertices of the rectangle on the sides  $AC$  and  $AB$  are the points  $(x : y + z : 0)$  and  $(x : 0 : y + z)$ .

The center of the rectangle is the point

$$A' = (a^2x : a^2(x + y + z) - S_Bx : a^2(x + y + z) - S_Cx).$$

Similarly, consider the two other rectangles with top edges through  $P$  parallel to  $CA$  and  $AB$  respectively, with centers  $B'$  and  $C'$ . The triangle  $A'B'C'$  is perspective with  $ABC$  if and only if

$$\begin{aligned} & (a^2(x + y + z) - S_Bx)(b^2(x + y + z) - S_Cy)(c^2(x + y + z) - S_Az) \\ &= (a^2(x + y + z) - S_Cx)(b^2(x + y + z) - S_Ay)(c^2(x + y + z) - S_Bz). \end{aligned}$$

The first terms of these expressions cancel one another, so do the last terms. Further cancelling a common factor  $x + y + z$ , we obtain the quadratic equation

$$\sum a^2 S_A (S_B - S_C) yz + (x + y + z) \sum_{\text{cyclic}} b^2 c^2 (S_B - S_C) x = 0.$$

---

$$^3 (v + w : \frac{v^2}{w+u} : \frac{w^2}{u+v}), (\frac{u^2}{v+w} : w + u : \frac{w^2}{u+v}), \text{ and } (\frac{u^2}{v+w} : \frac{v^2}{w+u} : u + v).$$

This means that the locus of  $P$  for which the centers of the inscribed rectangles form a perspective triangle is a hyperbola in the pencil generated by the Jerabek hyperbola

$$\sum a^2 S_A (S_B - S_C) yz = 0$$

and the Brocard axis  $OK$

$$\sum_{\text{cyclic}} b^2 c^2 (S_B - S_C) x = 0.$$

Since the Jerabek hyperbola is the isogonal transform of the Euler line, it contains the point  $H^* = O$  and  $G^* = K$ . The conic therefore passes through  $O$  and  $K$ . It also contains the de Longchamps point  $L = (-S_{BC} + S_{CA} + S_{AB} : \dots : \dots)$  and the point  $(S_B + S_C - S_A : S_C + S_A - S_B : S_A + S_B - S_C)$ .<sup>4</sup>

$P$	Perspector
circumcenter	$(\frac{1}{2S^2 - S_{BC}} : \frac{1}{2S^2 - S_{CA}} : \frac{1}{2S^2 - S_{AB}})$
symmedian point	$(3a^2 + b^2 + c^2 : a^2 + 3b^2 + c^2 : a^2 + b^2 + 3c^2)$
de Longchamps point	$(S_{BC}(S^2 + 2S_{AA}) : \dots : \dots)$
$(3a^2 - b^2 - c^2 : \dots : \dots)$	$(\frac{1}{S^2 + S_{AA} + S_{BC}} : \dots : \dots)$

**Exercises**

1. Show that the three inscribed rectangles are similar if and only if  $P$  is the point

$$\left( \frac{a^2}{t + a^2} : \frac{b^2}{t + b^2} : \frac{c^2}{t + c^2} \right),$$

where  $t$  is the unique positive root of the cubic equation

$$2t^3 + (a^2 + b^2 + c^2)t^2 - a^2b^2c^2 = 0.$$

**12.2 Lines simultaneously bisecting perimeter and area**

Recall from §11.3 that the  $A$ -area-bisecting lines envelope the conic whose dual is represented by the matrix

$$M_1 = \begin{pmatrix} 2 & 1 & 1 \\ 1 & 0 & -1 \\ 1 & -1 & 0 \end{pmatrix}.$$

---

<sup>4</sup>None of these perspectors appears in the current edition of ETC.

On the other hand, the  $A$ -perimeter-bisecting lines envelope another conic whose dual is represented by

$$M_2 = \begin{pmatrix} 2(s-a) & s-b & s-c \\ s-b & 0 & -s \\ s-c & -s & 0 \end{pmatrix}.$$

To find a line simultaneously bisecting the area and perimeter, we seek an intersection of the two dual conics represented by  $M_1$  and  $M_2$ . In the pencil of conics generated by these two, namely, the conics represented by matrices of the form  $tM_1 + M_2$ , there is at least one member which degenerates into a union of two lines. The intersections of the conics are the same as those of these lines with any one of them. Now, for any real parameter  $t$ ,

$$\begin{aligned} \det(tM_1 + M_2) &= \begin{vmatrix} 2(t+s-a) & t+s-b & t+s-c \\ t+s-b & 0 & -(t+s) \\ t+s-c & -(t+s) & 0 \end{vmatrix} \\ &= -2(t+s)(t+s-b)(t+s-c) - 2(t+s)^2(t+s-a) \\ &= -2(t+s)[(t+s-b)(t+s-c) + (t+s)(t+s-a)] \\ &= -2(t+s)[2(t+s)^2 - 2s(t+s) + bc] \end{aligned}$$

By choosing  $t = -s$ , we obtain

$$-sM_1 + M_2 = \begin{vmatrix} -2a & -b & -c \\ -b & 0 & 0 \\ -c & 0 & 0 \end{vmatrix}$$

which represents the degenerate conic

$$2ax^2 + 2bxy + 2cxy = 2x(ax + by + cz) = 0.$$

In other words, the intersections of the two dual conics are the same as those

$$x^2 + xy + xz - yz = 0$$

(represented by  $M_1$ ) and the lines  $x = 0$  and  $zx + by + cz = 0$ .

(i) With  $x = 0$  we obtain  $y = 0$  and  $z = 0$ , and hence the points  $(0 : 0 : 1)$  and  $(0 : 1 : 0)$  respectively on the dual conic. These correspond to the line

This means that such a line must pass through the incenter  $I$ , and as an area-bisecting line,

$$2bt^2 - (a + b + c)t + c = 0,$$

and

$$t = \frac{(a + b + c) \pm \sqrt{(a + b + c)^2 - 8bc}}{4b} = \frac{s \pm \sqrt{s^2 - 2bc}}{2b}.$$

The division point on  $AC$  are

$$(1 - t : 0 : t) = (2b - s \mp \sqrt{s^2 - 2bc} : 0 : s \pm \sqrt{s^2 - 2bc}).$$

### 12.3 Parabolas with vertices of a triangle as foci and sides as directrices

Given triangle  $ABC$ , consider the three parabolas each with one vertex as focus and the opposite side as directrix, and call these the  $a$ -,  $b$ -, and  $c$ -parabolas respectively. The vertices are clearly the midpoints of the altitudes. No two of these parabolas intersect. Each pair of them, however, has a unique common tangent, which is the perpendicular bisector of a side of the triangle. The three common tangents therefore intersect at the circumcenter.

The points of tangency of the perpendicular bisector  $BC$  with the  $b$ - and  $c$ -parabolas are inverse with respect to the circumcircle, for they are at distances  $\frac{bR}{c}$  and  $\frac{cR}{b}$  from the circumcenter  $O$ . These points of tangency can be easily constructed as follows. Let  $H$  be the orthocenter of triangle  $ABC$ ,  $H_a$  its reflection in the side  $BC$ . It is well known that  $H_a$  lies on the circumcircle. The intersections of  $BH_a$  and  $CH_a$  with the perpendicular bisector of  $BC$  are the points of tangency with the  $b$ - and  $c$ -parabolas respectively.

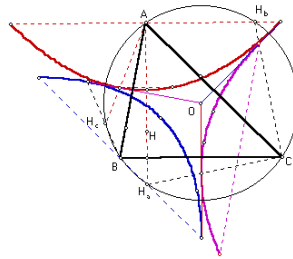

### Exercises

1. Find the equation of the  $a$ -parabola.<sup>5</sup>

## 12.4 The Soddy hyperbolas

### 12.4.1 Equations of the hyperbolas

Given triangle  $ABC$ , consider the hyperbola passing through  $A$ , and with foci at  $B$  and  $C$ . We shall call this the  $a$ -Soddy hyperbola of the triangle, since this and related hyperbolas lead to the construction of the famous Soddy circle. The reflections of  $A$  in the side  $BC$  and its perpendicular bisector are clearly points on the same hyperbola, so is the symmetric of  $A$  with respect to the midpoint of  $BC$ . The vertices of the hyperbola on the transverse axis  $BC$  are the points  $(0 : s - b : s - c)$ , and  $(0 : s - c : s - b)$ , the points of tangency of the side  $BC$  with the incircle and the  $A$ -excircle.

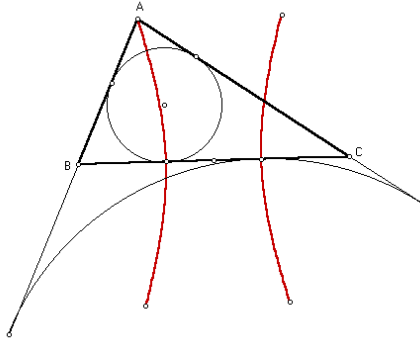

Likewise, we speak of the  $B$ - and  $C$ -Soddy hyperbolas of the same triangle, and locate obvious points on these hyperbolas.

### 12.4.2 Soddy circles

Given triangle  $ABC$ , there are three circles centered at the vertices and mutually tangent to each other externally. These are the circles  $A(s - a)$ ,  $B(s - b)$ , and  $C(s - c)$ . The *inner Soddy circle* of triangle  $ABC$  is the circle tangent externally to each of these three circles. The center of the inner Soddy circle clearly is an intersection of the three Soddy hyperbolas.

---

<sup>5</sup> $-S^2x^2 + a^2(c^2y^2 + 2S_Ayz + b^2z^2) = 0.$



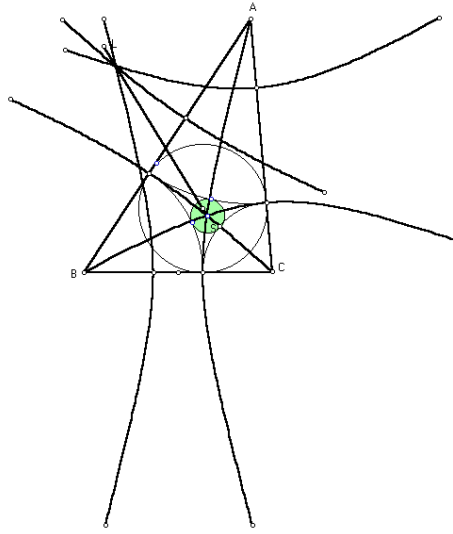

### Exercises

1. Show that the equation of  $A$ -Soddy hyperbola is

$$F_a = (c + a - b)(a + b - c)(y^2 + z^2) - 2(a^2 + (b - c)^2)yz + 4(b - c)cxy - 4b(b - c)zx = 0.$$

## 12.5 Appendix: Constructions with conics

Given 5 points  $A, B, C, D, E$ , no three of which are collinear, and no four concyclic, the conic  $\mathcal{C}$ . Through these 5 points is either an ellipse, a parabola, or a hyperbola.

### 12.5.1 The tangent at a point on $\mathcal{C}$

- (1)  $P := AC \cap BD$ ;
  - (2)  $Q := AD \cap CE$ ;
  - (3)  $R := PQ \cap BE$ .
- $AR$  is the tangent at  $A$ .

### 12.5.2 The second intersection of $\mathcal{C}$ and a line $\ell$ through $A$

- (1)  $P := AC \cap BE$ ;
- (2)  $Q := \ell \cap BD$ ;

- (3)  $R := PQ \cap CD$ ;
  - (4)  $A' := \ell \cap ER$ .
- $A'$  is the second intersection of  $\mathcal{C}$  and  $\ell$ .

### 12.5.3 The center of $\mathcal{C}$

- (1)  $B' :=$  the second intersection of  $\mathcal{C}$  with the parallel through  $B$  to  $AC$ ;
- (2)  $\ell_b :=$  the line joining the midpoints of  $BB'$  and  $AC$ ;
- (3)  $C' :=$  the second intersection of  $\mathcal{C}$  with the parallel through  $C$  to  $AB$ ;
- (4)  $\ell_c :=$  the line joining the midpoints of  $CC'$  and  $AB$ ;
- (5)  $O := \ell_b \cap \ell_c$  is the center of the conic  $\mathcal{C}$ .

### 12.5.4 Principal axes of $\mathcal{C}$

- (1)  $K(O) :=$  any circle through the center  $O$  of the conic  $\mathcal{C}$ .
  - (2) Let  $M$  be the midpoint of  $AB$ . Construct (i)  $OM$  and (ii) the parallel through  $O$  to  $AB$  each to intersect the circle at a point. Join these two points to form a line  $\ell$ .
  - (3) Repeat (2) for another chord  $AC$ , to form a line  $\ell'$ .
  - (4)  $P := \ell \cap \ell'$ .
  - (5) Let  $KP$  intersect the circle  $K(O)$  at  $X$  and  $Y$ .
- Then the lines  $OX$  and  $OY$  are the principal axes of the conic  $\mathcal{C}$ .

### 12.5.5 Vertices of $\mathcal{C}$

- (1) Construct the tangent at  $A$  to intersect to the axes  $OX$  and  $OY$  at  $P$  and  $Q$  respectively.
- (2) Construct the perpendicular feet  $P'$  and  $Q'$  of  $A$  on the axes  $OX$  and  $OY$ .
- (3) Construct a tangent  $OT$  to the circle with diameter  $PP'$ . The intersections of the line  $OX$  with the circle  $O(T)$  are the vertices on this axis.
- (4) Repeat (3) for the circle with diameter  $QQ'$ .

### 12.5.6 Intersection of $\mathcal{C}$ with a line $\mathcal{L}$

Let  $F$  be a focus,  $\ell$  a directrix, and  $e =$  the eccentricity.

- (1) Let  $H = \mathcal{L} \cap \ell$ .
- (2) Take an arbitrary point  $P$  with pedal  $Q$  on the directrix.
- (3) Construct a circle, center  $P$ , radius  $e \cdot PQ$ .

- (4) Through  $P$  construct the parallel to  $\mathcal{L}$ , intersecting the directrix at  $O$ .
- (5) Through  $O$  construct the parallel to  $FH$ , intersecting the circle above in  $X$  and  $Y$ .
- (6) The parallels through  $F$  to  $PX$  and  $PY$  intersect the given line  $\mathcal{L}$  at two points on the conic.